



# TYPE4 Checker Instruction Manual



Global Service Department

June, 2019

**DAIKIN INDUSTRIES, LTD.**

# Table of contents

Introduction		2
Chapter 1	Overview and preparation	3
	1-1 What's the service checker?	3
	1-2 Preparation	5
	1-2-1 Essential materials	5
	1-2-2 Other materials to prepare	6
	1-2-3 Required to do before recording	7
Chapter 2	Installing the checker software	9
	2-1 Obtainment of software (new/update)	9
	2-2 Installation procedure	9
	2-3 Removal of software	13
	2-3-1 From Windows control panel	13
Chapter 3	Connecting to the unit	15
	3-1 D3-NET (F1,F2) connection	15
	3-2 Connecting power supply	16
Chapter 4	Overview of the checker software	17
	4-1 Start up the checker software	17
	4-2 Quit the checker software	17
	4-3 Overview of the checker software function	18
Chapter 5	Recording operation data	19
	5-1 Viewing operation data	19
	5-1-1 Customer info selection	19
	5-1-2 Network map display	22
	5-1-3 Switching modes	24
	5-1-4 Detailed info input	26
	5-1-5 Operation data display	28
	5-2 Recording setup	32
	5-2-1 Setup recording	32
	5-3 Centralized operation	34
Chapter 6	Playback of recorded operation data	36
	6-1 Playing operation data	36
	6-2 Viewing customer/network map information	39
	6-3 CSV output (export function)	41
Chapter 7	Other functions	43
	7-1 Data transfer	43
	7-2 Customer information	45
	7-3 Option setting	46
	7-3-1 Setup COM port	46
	7-3-2 Prohibit/permit centralized control	47
	7-3-3 Change display language	48
	7-3-4 Change display unit of measure	48
	7-4 Help function	49
	Frequently asked questions	51
	Specification	55

# Introduction

Thank you for purchasing TYPE4 Checker.

This document instructs how to use TYPE4 Checker and Windows PC software for TYPE4 Checker (TYPE4 software). Please read carefully this document before using and use for correct use.

There could be a risk of unexpected accidents unless respecting cautions in this document.

## **[Instructions for your safety]**

In this document;

items which could result fatal damage unless respecting are marked as [WARNING],

items which could result serious damage to equipment are marked as [CAUTION].

Functions, ways to use this software, and supported VRV models by this software are different based on software version. In this document, instructions are targeted at V1.2.1.1 or later version.

PC software for TYPE3 Checker does not work with TYPE4 Checker. If you have not installed TYPE4 software to your PC, please obtain it before using.

To obtain the latest information (manual, software), please check on Daikin Europe Business Portal:  
<https://my.daikin.eu>

The contents of this document could be updated without precautions.

The contents of this document is not allowed to reprint without permissions.

# Chapter 1: Overview and preparation

## 1-1 What's the service checker?

### 1) Overview

Service checker is the tool which visualizes operation data (sensor readings, actuator status, operation mode, etc.) of VRV air conditioning units.

### 2) Composition

Service checker consists of two main components (TYPE4 checker box, TYPE4 checker software). It works with Windows PC which is connected to TYPE4 checker box by USB cable. It is necessary to install TYPE4 checker software to your Windows PC before using.

- TYPE4 checker components (see 1-2-1 Essential materials)
- Windows PC (see 1-2-2 Other materials to prepare)

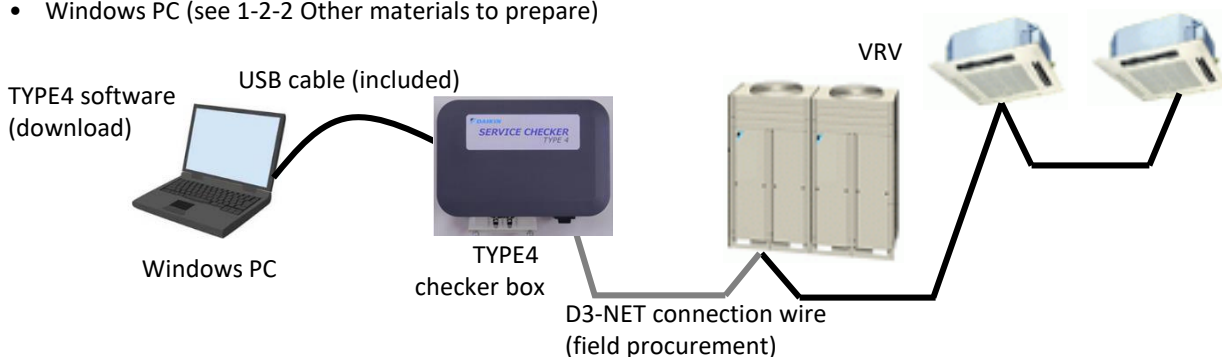

[Software update]

Supporting new VRV models is realized by PC software, so it is necessary to update TYPE4 checker software for supporting newly introduced products.

### 3) Purpose

- Troubleshooting, diagnosis of VRV systems (supporting diagnosis by visualized operation data)
- Commissioning of VRV systems (checking number of connected indoor units, operation condition check)

(Note) This tool is not designed for permanent installation such as continuous monitoring or long term data logging and such ways of using are not guaranteed. If a permanent monitoring is necessary, please consider using remote monitoring service.

### 4) How to obtain TYPE4 checker box

This tool is distributed as service part from local affiliate/distributor of Daikin. Please contact your local Daikin affiliate/distributor for purchasing TYPE4 checker box as the other spare parts.

## 5) TYPE4 checker details

USB2.0 port (Type-B)  
For communication with Windows PC or power supply by PC USB port or AC adapter (5V)



D3-NET connection  
port



Main switch

Main switch	Red colored LED will lit if you toggle this switch.
USB 2.0 port (Type-B)	Connecting to Windows PC by USB cable. This port is for power supply (5VDC) from PC USB port and communication with PC. * Please use the USB cable which is included in the TYPE4 package.
D3-NET connection port	Connection port for D3-NET communication cable. (This is not for power supply terminal, please do not apply power line. If you connect power supply to this port, TYPE4 Checker box will be broken and burnt.)

## 1-2 Preparation

Preparations for materials to be necessary for VRV operation data recording will be explained in this section.

1-2-1: Essential materials (TYPE4 checker)

1-2-2: D3-NET cable

### 1-2-1 Essential materials

Standard components which are required for VRV operation data recording are below.

#### 1. TYPE4 Checker box (Part number: 999176T)

##### (1) TYPE4 Checker box



##### (2) USB cable



Connection cable for connecting Checker and PC  
(USB Type B - USB Type A)  
: standard USB cable

## 1-2-2 Other materials to prepare

### 1) Required PC specification

#### •PC type

- Windows PC
- CPU 1GHz+, Memory 2GB+, HDD 20GB+
- Windows7 SP1 or later, Windows 8.0 /8.1 /10
- USB port

### 2) D3-NET connection cable

D3-NET connection cable does not come with TYPE4 Checker package. Please prepare below cable to connect TYPE4 Checker and VRV D3-NET port.

(1) Prepare the following signal wires. (Refer to the below notes.)

When connecting to an outdoor unit, it is appropriate for the signal wires to have 2 m in length. When connecting to an indoor unit or wiring indoor from the outdoor unit, it is possible to lengthen the signal wires within the limits of the D3-NET length.

For control signal wiring, use vinyl cords or cables with two-core and sheathed as follow.

•Vinyl cabtyre cylindrical cord	VCTF	JISC3306
•Vinyl-insulated vinyl sheathed cable for control	CVV	JISC3401
•Vinyl-insulated vinyl sheathed, cylindrical cable for control	CVS	JISC3401
•Vinyl-insulated vinyl sheathed, cylindrical cable	VVR	JISC3342
•600V vinyl cabtyre cable	VCT	JISC3312

#### Cautions:

1. Do not use multiple-cored wires with 3 cores or more.
2. Use wires with a cross section of 0.75mm<sup>2</sup> -1.25mm<sup>2</sup>.
3. Do not make wires bound in control- signal wiring. Do not make long-distance wiring by having signal wires bound packed with tapes, tie-laps and the like.
4. Wire the signal wires away from power lines to prevent the effects of electric noise. Since Daikin's air conditioners and related products will generate much lower electric noises, it allows to have a distance of minimum 50mm between the power lines and the control signal wires.

#### (2) D3-NET connection terminal specification of TYPE4 Checker

For D3-NET communication wire connection, wire terminal listed below are recommended (M3 type screw is used for terminal)

- R1.25-3 (JIS)
- R1.25-3.5 (JIS)
- R2-3.5 (JIS)

In case of use circular shaped wire terminal, please select wire terminal which fits this terminal block.

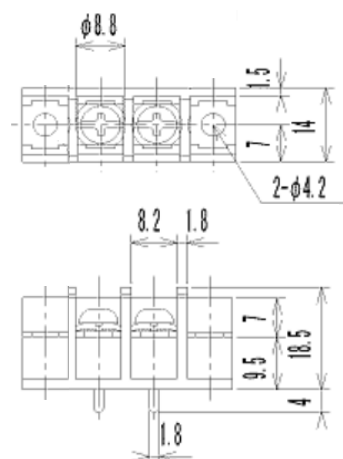

## 1-2-3 Required to do before recording

After finishing preparation of materials, further preparation is needed for executed as the listed procedure.

- 1) TYPE4 software installation (setup)
- 2) Connecting PC and Checker
- 3) Confirmation of connection
- 4) Check of supported models

### 1) TYPE4 software installation (setup)

Following the instruction of Chapter 2 (Installing the checker software), install checker software.

### 2) Connecting PC and Checker

Connect PC and Checker by the USB cable included in the Checker package.

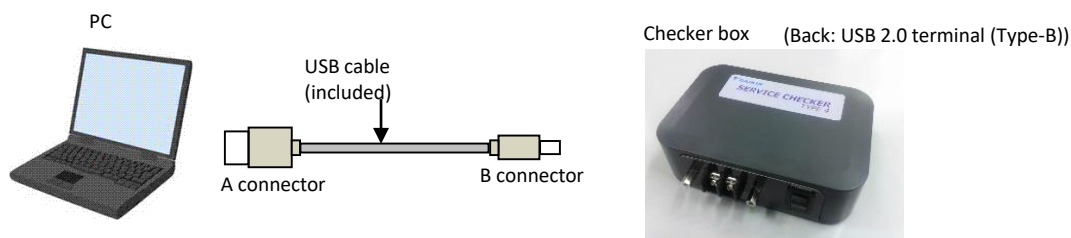

### 3) Confirmation of connection

To avoid troubles such as PC and Checker connection, please check connection between PC and Checker as instructions listed below.

[How to confirm]

Connection check can be done without connecting checker and VRV.

[Confirmation procedure]

- Connect PC and Checker, turn on Checker
- Start Checker software
- Select correct COM port which is connected to Checker (default selection is COM1)

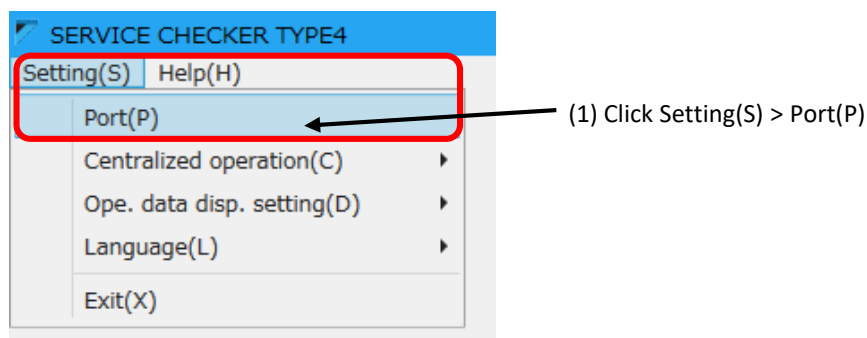



(2) Select COM port to be used in Select Port window

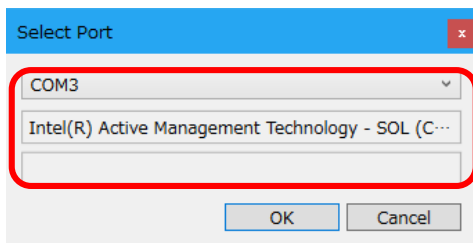

Click top box and select COM port number to use.  
Please select COM port number which shows “Silicon Labs CP210x USB to UART Bridge” in the 2nd box.  
COM port number is different from PC.

(Note) In case of no COM port with “Silicon Labs CP210x USB to UART Bridge”

It is necessary to install USB port device driver.

Please obtain correct device driver from vendor website.

<https://www.silabs.com/products/development-tools/software/usb-to-uart-bridge-vcp-drivers>

(3) Click OK button to proceed.

- Press “Record” in main menu
- Click “Record only” in Customer Selection window
- Enter any names in network map name box and press OK button to proceed.
- Please below check in network map window.

[OK case]

Wait for about 10sec, if there will be no [Not OK case] messages shown, connection is OK.

[Not OK case]

Wait for about 10sec, if there will be messages like “Port could not be opened”, “It could not be started, please check connection” are shown, communication was not executed correctly. Please go back (exit) once and check COM port setting in option menu. Then please check again.

#### 4) Check of supported models

[Supported model list]

- In HELP menu of Checker software

# Chapter 2: Installing the checker software

## 2-1 Obtainment of software (new/update)

Please obtain checker software from your Local Daikin Affiliate Business Portal webpage or ask your local Daikin affiliate/ distributor.

(Reference) Daikin Europe Business Portal:

<https://my.daikin.eu>

- Software update

When new VRV models introduced, it could be necessary to update checker software to check operation data of new model.

## 2-2 Installation procedure

1) Please download from Daikin Business Portal and execute installation file on your PC folder.

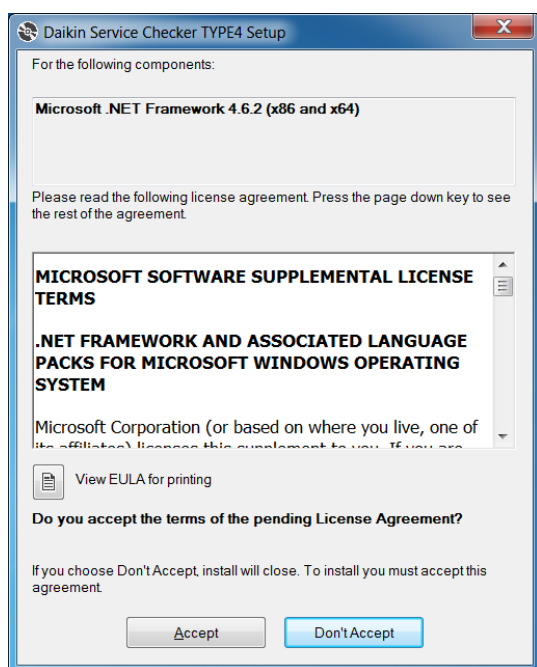

2) Installer program will start.

If .NET Framework 4.6.2 or higher is not installed in your PC, installation of .NET Framework 4.6.2 will start.

If it is already installed, move to (4).

Please click Accept button to proceed.

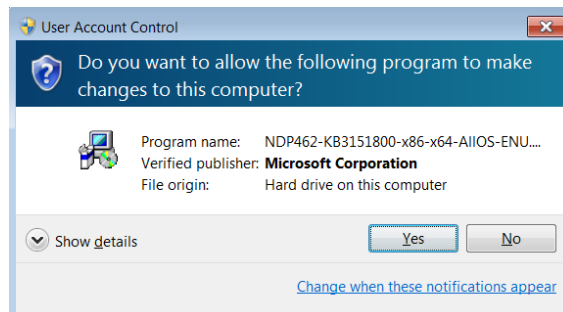

If above message will be shown, press OK button to proceed.

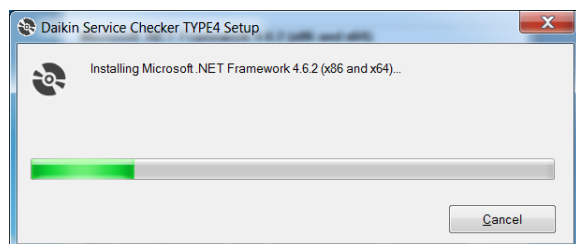

3) Installation will start, please wait for completion.

Move to (4) after installation completed.

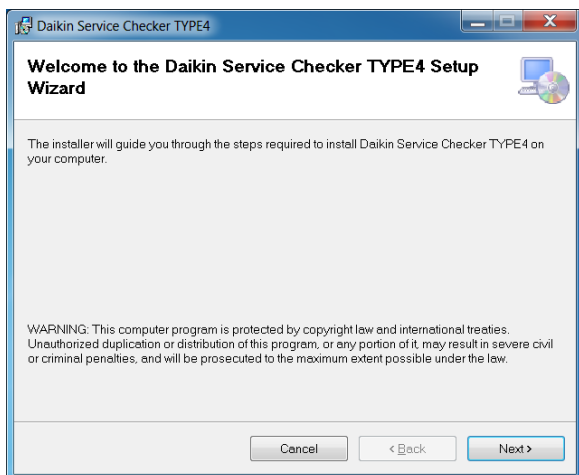

4) Installation of checker software starts.

Please click [Next] button.

- If the old version software is installed it will be overwritten by newer version.
- If the same version is installed, move to (10).

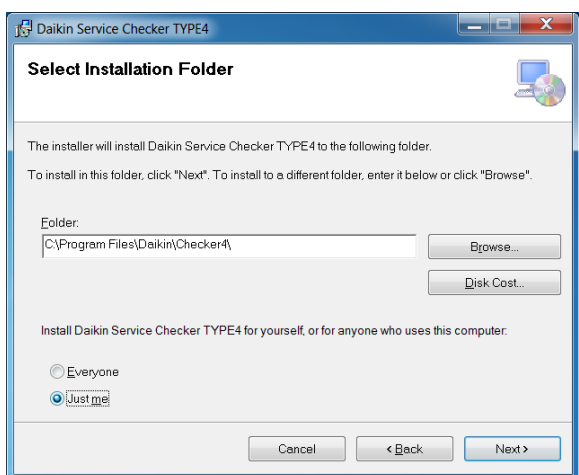

5) Select destination folder to install

If you do not change, software will be installed to the below folder.

- 32bit OS: C:\Program Files\Daikin\Checker4\
- 64bit OS: C:\Program Files(x86)\Daikin\Checker4\

To change installation folder, please install after change the system setting.

\* If you do not have the administrator rights, installation might not be executed. Please consult with your PC administrator such as IT department for further support.

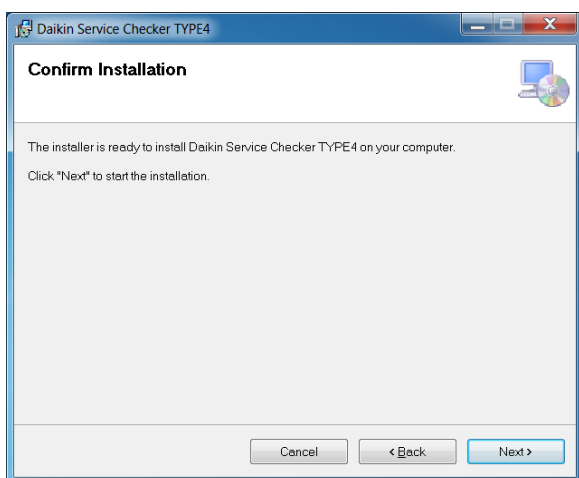

6) Click [Next] button to proceed

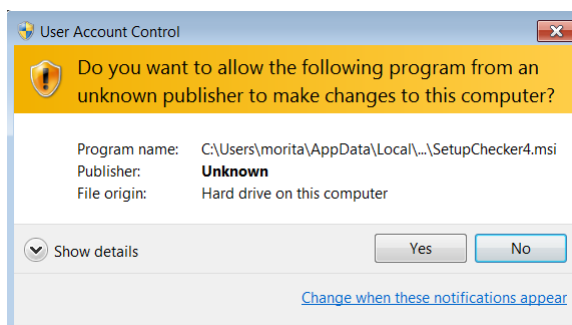

If above screen will be shown, please press Yes to proceed.

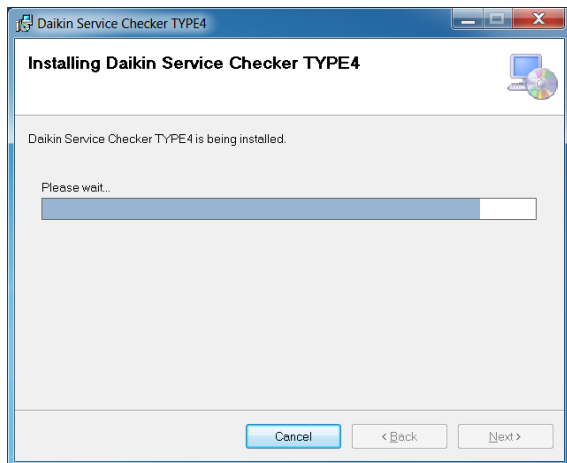

7) When installation started, wait for the completion.

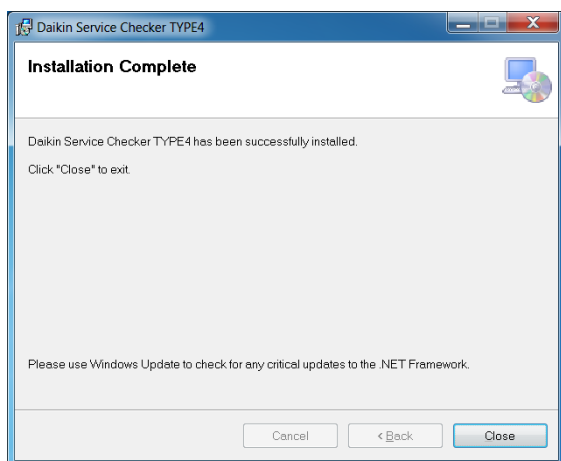

8) Installation completed

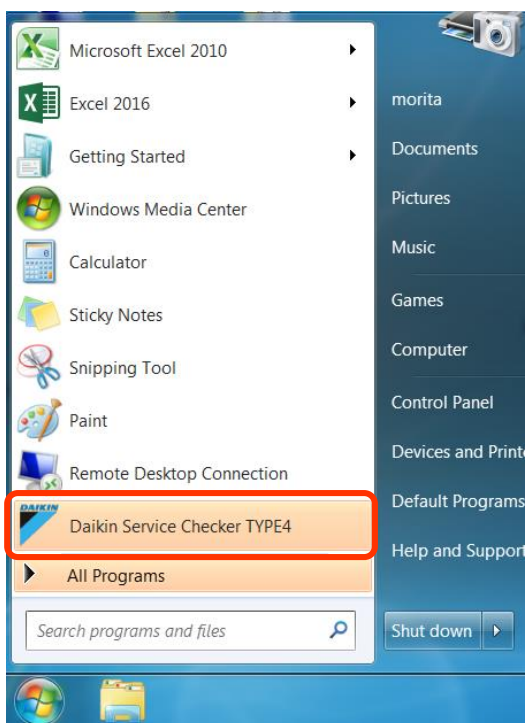

9) In start menu, “Daikin Service Checker TYPE4” will be added under “Daikin” folder and desktop.

\* Left picture is a sample of Windows7 PC

\* Looks of start menu display could differ from Windows version and PC situation.

## [Removal of software (uninstallation)]

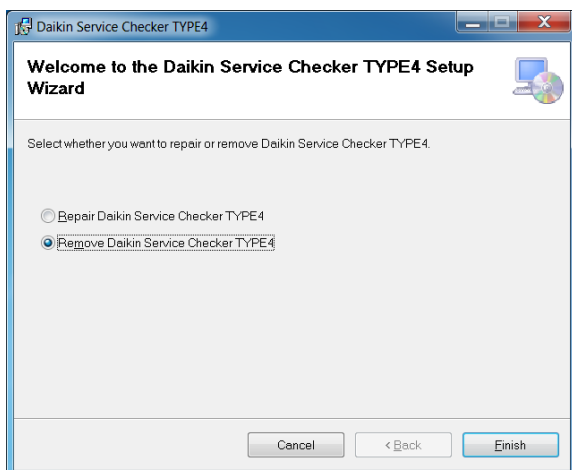

10) If the same version software is installed, left window will be shown.

Select Remove and press "Finish"

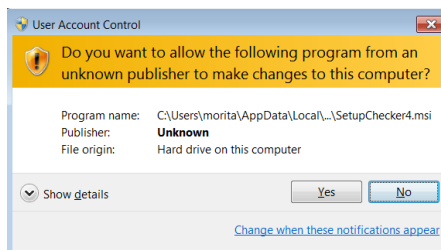

If above screen will be shown, press Yes to proceed.

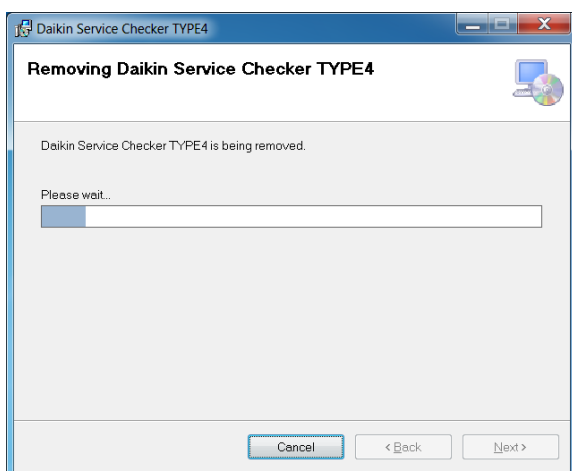

11) Software will be removed.

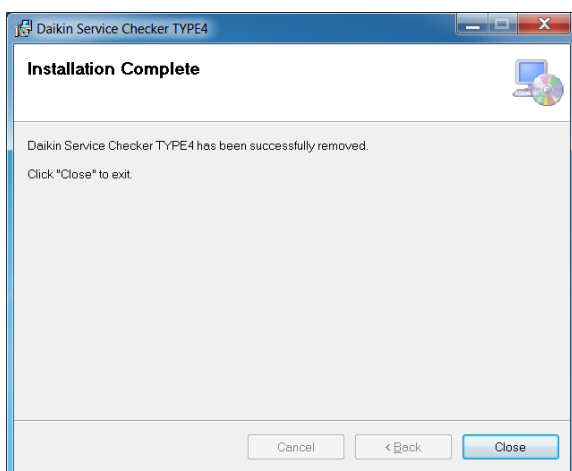

12) Software has been removed.

**(Note)**

\* Even if the software will be removed, recorded data will remain. You can utilize them once you'll install the software.

## 2-3 Removal of software

### [Overview]

There are two options for software removal.

- 1) From Windows control panel
- 2) By checker installation file  
(instructed by step (10) of 2-2 Installation procedure)

### 2-3-1 From Windows control panel

Use this option if there is not installation file in your PC.

(It is easier to uninstall from installer file for update)

Procedure will be explained in below procedure with Windows7 and Windows10 sample.

### [Procedure]

- 1) Select Control panel of Windows

#### [Windows7]

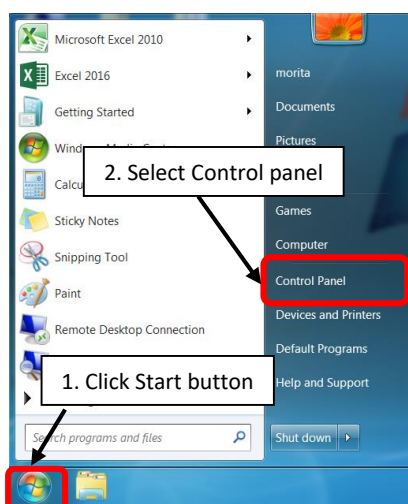

#### [Windows10]

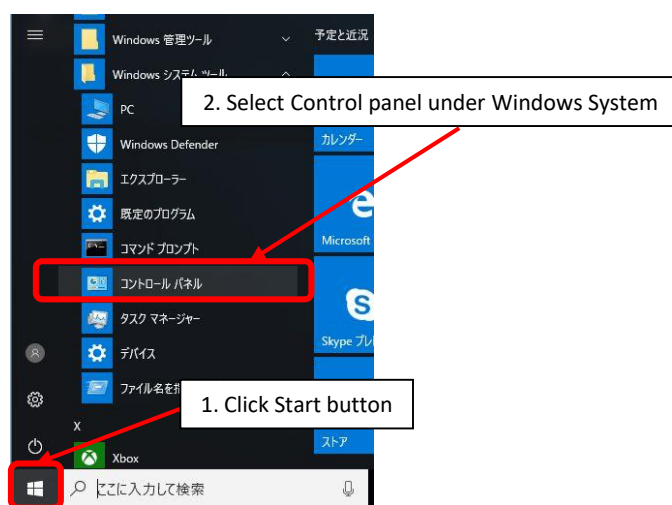

- 2) Double click Program

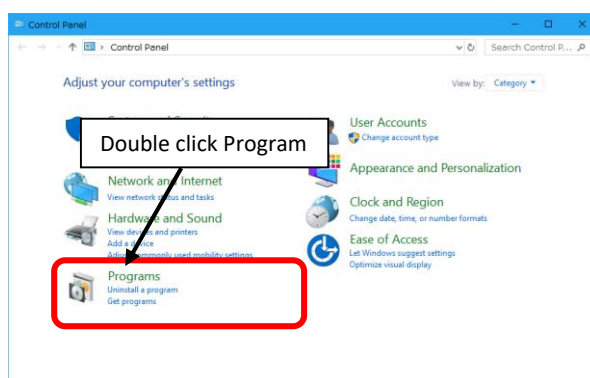
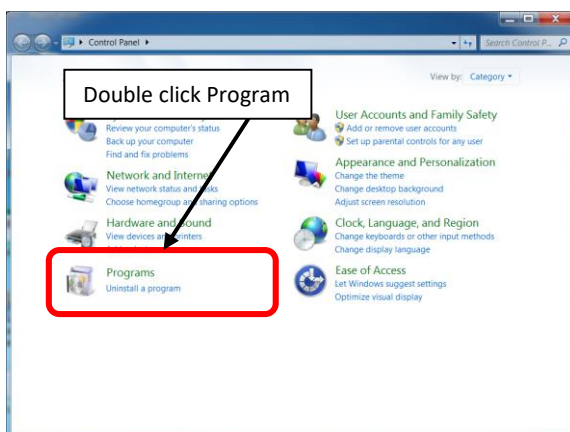

## 3) Select Daikin Service Checker TYPE4 and click Uninstall

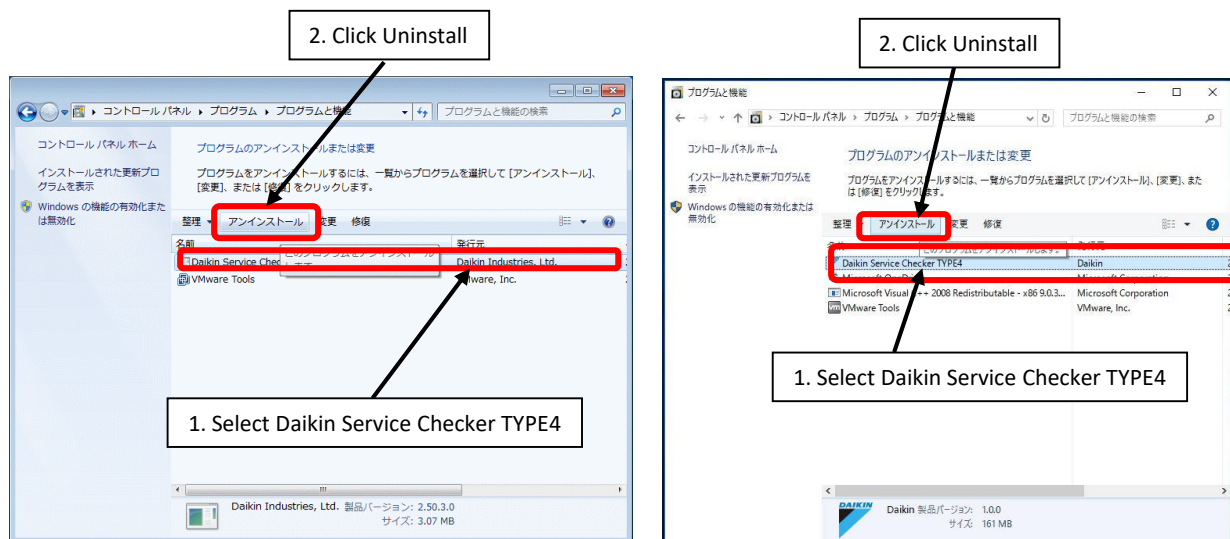

After this point, uninstall process will start. This process is same for Windows7 and 10.

Please carry out uninstallation process by following instruction.

(Please follow instructions for the OS other than Winsows7 and 10)

## (Note)

\* Even if the software will be removed, recorded data will remain. You can utilize them once you'll install the software.

## Chapter 3: Connecting to the unit

### [Warning]

In case of long term logging or using in the outdoor under rainy weather, please take appropriate countermeasure for protection from rainwater to avoid electric shock or fire.

### 3-1 D3-NET (F1,F2) connection

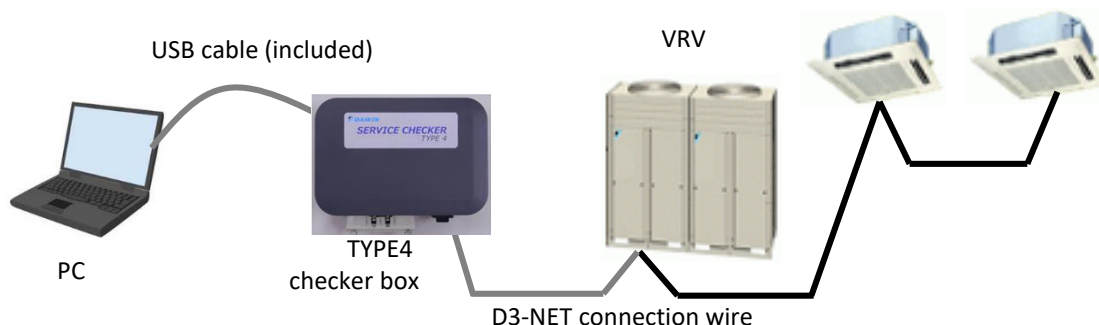

### [Connection procedure]

- (1) Connect with D3-NET connection wire prepared in 1-2 Preparation part in this manual. Please connect wire to D3-NET terminal of checker first. (If connect to D3-NET terminal of VRV and F1-F2 will be short-circuited, unit could be damaged)
- (2) Connect another end of D3-NET connection wire to communication terminal (F1-F2) of VRV unit.

### [Warning]

Please connect to communication terminal of VRV (outdoor unit or indoor unit) or centralized controller. If it would be connected to power terminal, there is a possibility of fatal accident by electric shock or damage of the unit.

### [Caution]

1. It's not necessary to correspond F1-F2 of the transmission terminal of VRV to F1-F2 of the checker like F1-F1 or F2-F2 respectively (no polarity).
2. Recommended connection point of VRV unit is F1-F2 terminal of OUT-OUT connection of outdoor unit, but it can be connected to indoor unit or centralized controller.
3. In case of connecting to indoor unit, please connect to the last indoor unit of the line to avoid sub-branching.
4. To extend wiring length (up to hundreds of meters), it could cause affection to the unit's operation. Please be aware of electric interference such as taking enough distance from power line.



### [Caution before using]

- When connecting to the VRV unit for the first time, the unit will change to stand-by mode for several minutes to scan all the connected indoor and outdoor units. The system will automatically resume after finishing auto-scanning (for 2nd time and onwards, system would not enter stand-by status by choosing saved network map).
- Data refresh interval depends on the refresh interval of connected VRV model (normally between 1 min to 5 min) regardless of data saving interval setting of checker software.
- In case of DTA109 adapter (D3-NET expander) is installed, Checker cannot collect operation data beyond the point of DTA109 (for example, if you connect Checker in main bus, operation data of VRV systems in branch bus cannot be monitored).
- If Wiring Adaptor for Electrical Appendices (1) or (2) (KRP2A or KRP4A) are installed to the same D3-NET line, an error will be displayed to BMS or other centralized control system. To avoid this error, it is necessary to prohibit centralized control function of checker software (see 7-3-2 Prohibit/permit centralized control).

## 3-2 Connection power supply

### [Procedure]

- (1) Please connect your PC to Checker USB port (Type-B) by the USB cable which came with Checker package.

#### [Caution]

Power is supplied from USB terminal. Do not connect AC power to D3-NET (F1,F2) terminal.  
(If AC power is connected to the D3-NET port, checker will be burned and broken.)

- (2) Please switch the Checker on. Red LED will be lit on power switch.

# Chapter 4: Overview of the checker software function

## 4-1 Start up the checker software

After installation of checker software, icon will be added to the Windows start menu.

[Procedure]

1) From (Start[ button, select [Program] and select checker software.

[ Windows 7 ]

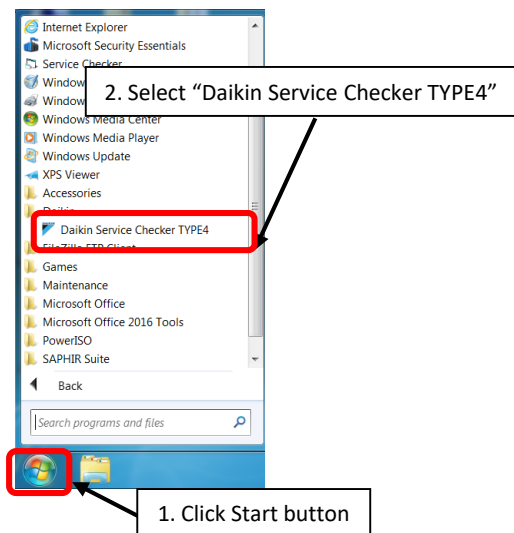

[ Windows 10 ]

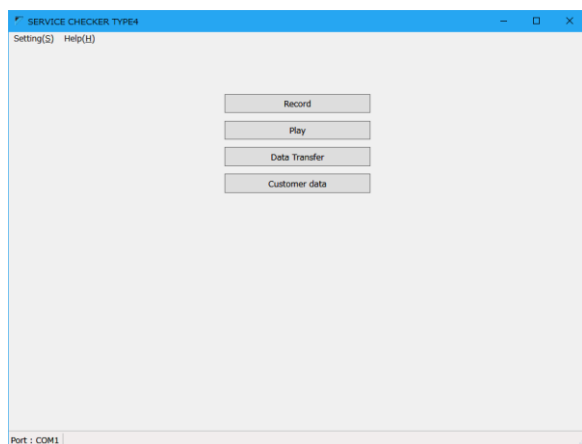
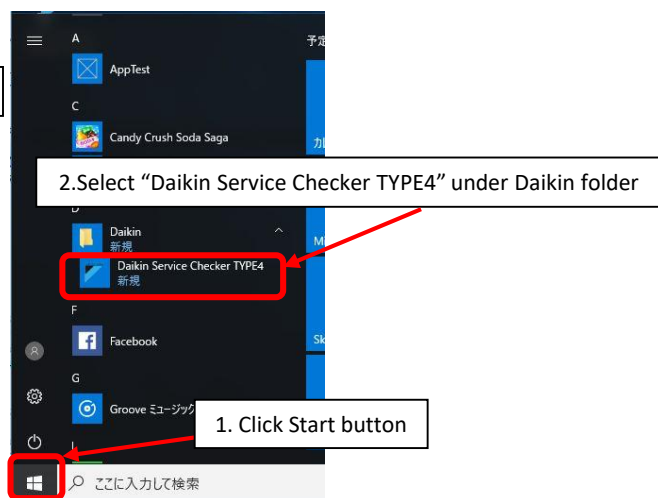

2) Checker software starts up and shows the main menu shown left.

(It looks same for both Windows7 and 10)

## 4-2 Quit the checker software

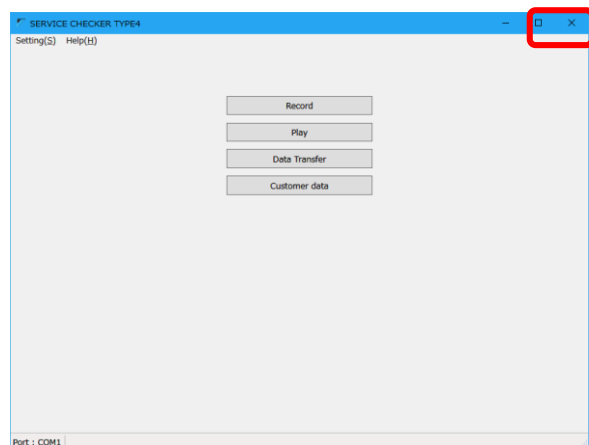

There are two ways to quit checker software.

1) Click "X" button on the top right corner.

2) By selecting “Setting”>”Exit”, checker software can be quit.

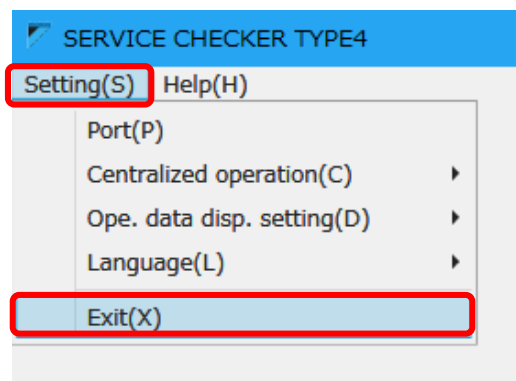

### 4-3 Overview of the checker software function

There are buttons listed below are in the checker software main menu.

[Record]	Use for monitoring/recording VRV operation data (Refer to Chapter 5)
[Play]	Use for checking/exporting recorded data (Refer to Chapter 6)
[Data Transfer]	Use for exporting/importing recorded data or customer information to/from other users or PC. (Refer to Chapter 7-1)
[Customer data]	Use for enter/edit customer information (please enter customer info for all the time). Saved network map information can be checked here. (Refer to Chapter 7-2 and 6-2)

# Chapter 5: Recording operation data

By [Record] menu, VRV operation data monitoring and recording (collecting data) can be executed. It is necessary to use this menu if case of only monitoring operation data without recording.

As shown in the right chart, data is managed as tree structure. From the top, data is categorized as “customer”, “network map (system)”, and “Operation data”.

Customer	Network map	Operation data
Customer A	Building E 1 <sup>st</sup> floor	System1: Mar.23
		System2: Mar.23
	:	:
	Building E 2 <sup>nd</sup> floor	System1: Apr.2
	:	:
Customer B	:	:
:	:	:

(Note) “Record only” without data management can be selected, it is recommended to use customer information for better management of each data.

## 5-1 Viewing operation data

### 5-1-1 Customer info selection

#### [Procedure]

(1) In main menu, click [Record] button. Proceeding to [Customer selection]

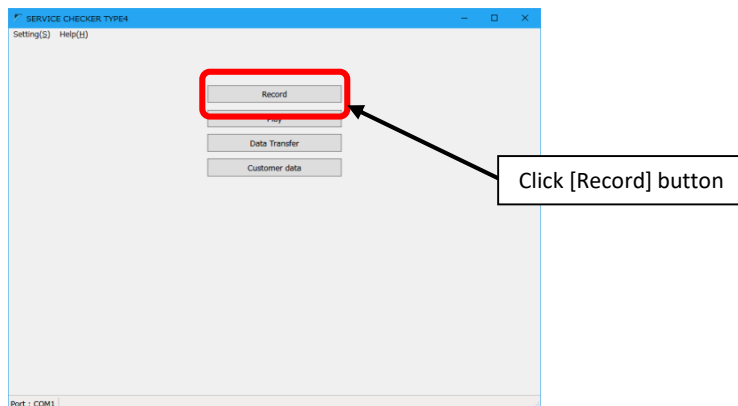

(2) Customer selection screen

Please enter customer information. Data recording can be executed without entry of customer information (Record only)

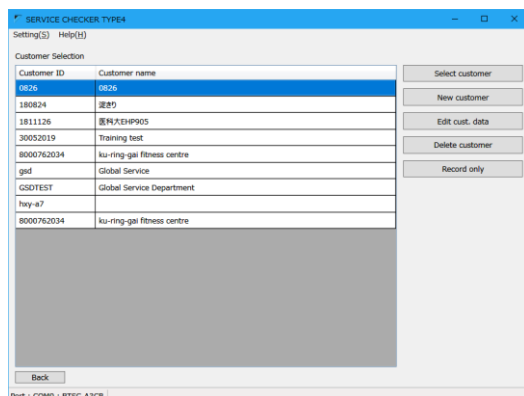

- Press [New customer] to record data for a new customer with registration of customer information. Proceeding to [Customer data input] screen. Please proceed to (3)
- To use existing customer information, please select desired customer and press [Select customer] button to proceed [Network map selection] screen. Please proceed to (4)
- To use edit and use existing customer information, please select desired customer and press [Edit cust. Data] button to proceed to [Edit cust. Data] screen. Please proceed to (3)
- In case of recording only without customer information management, please press [Record only] button. Please proceed to (5)

**(Note)**

1. In case of [Record only], operation data will be overwritten every time. Please be aware.
2. In case of [Record only], VRV system will stand by every time. So it is recommended to enter customer information to avoid unnecessary system stand-by.

- To delete existing customer, please press [Delete customer] button
- To return to main menu, please press [Back] button in the bottom left corner.

(3) [Customer data input] screen. Please enter customer information.

Customer ID	007
Customer name	Daikin Industries, LTD.
Section	
Person in charge	
Address	
Telephone	
Customer FAX number	
Remarks	

- [Customer ID] is mandatory field
- [Customer name] is used in [Operation data selection] screen, so please use clear name.
- For the other items, please enter in case of necessity.

After entry of all information, please press [Save] button. By pressing [Select customer] button, you can go to [Network map selection] screen. If you need to return without saving, please press [Cancel] button.

(4) [Network map selection] screen

Map name	Model name	Date
Map for hvys17		2015/12/01
Map Daikin1.rnyq137		2015/12/01

- Select desired network map (D3-NET line name).
- Select [New] or {OK} to use selected existing map.

**(Note)**

1. It is possible to manage multiple network map info under one customer name.
2. One D3-NET line is managed as one network map, but it is necessary to manage D3-NET line which is split by DTA109 as different network map.

- If there is network map which used for operation data recording in the past, please select desired network map and press [OK] button to proceed to [Network map] screen. Please proceed to [5-1-2: Network map display]
- Even if in the site where you have recorded operation data before, if you are connecting to the different D3-NET system please press [New] button. Please proceed to (5)
- To change the name of existing network map, please press [Edit map name] button. Please proceed to (6)
- To delete existing network map, please press [Delete] button
- To return, please press [Back] button

#### (5) Confirmation screen for new connection

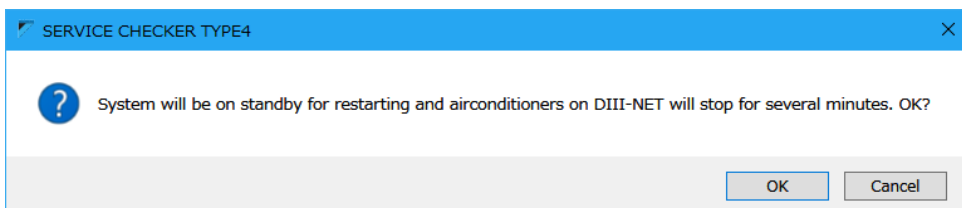

In case of first time connection to D3-NET, connected system will be in stand-by status to obtain line and model (series) information from D3-Net with notification screen shown above. If the system can be changed to stand-by status, please press [OK] button to proceed to (6)

#### (Note)

1. By pressing [OK] button of (6) [Edit map name screen], system will be in stand-by status and will be thermostat-off for several minutes.
2. If you use existing network map which was created before, confirmation screen would not shown for the 2<sup>nd</sup> time.

#### (6) [Edit map name] screen

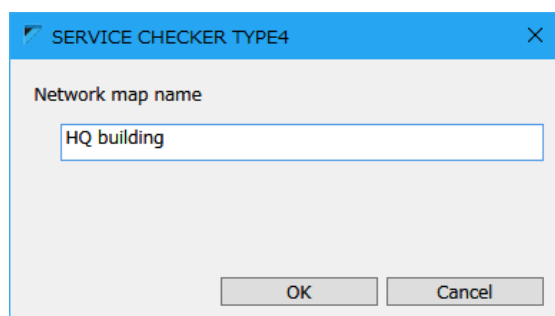

1) Enter network map name (mandatory)

2) After entering appropriate network map name, please press [OK] button to proceed [Network map display] screen. Then proceed to [5-1-2 Network map display]. Please press [Back] button to return.

## 5-1-2 Network map display

Data will be collected upon the confirmation of previous screen.

Status of data collection will be shown as icon in the network map.

Checker software scans connected equipment in the D3-NET line for several minutes.

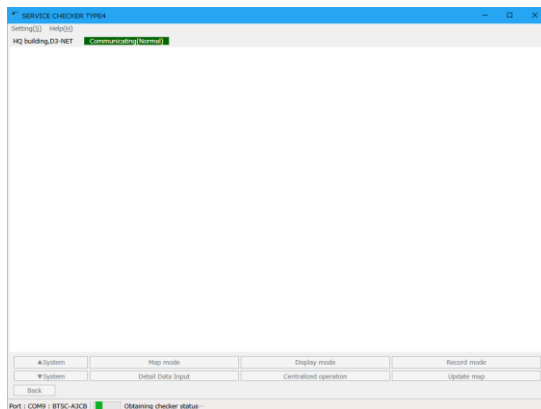

### (Note1)

- Without initialization of D3-NET line after adding/removing outdoor unit, indoor unit, BS unit or replacing control PCB, network map cannot be shown. In those cases please carry out D3-NET initialization before using checker.
- In case of system stand-by is not allowed, please use past existing network map or carry out in the hours system stand-by is allowed.

### (Note2)

- If you change date/time setting of PC after the point of [Network map display] screen, the order of recorded data could be mixed up and would not be recorded correctly. To avoid such an issue, please do not change date/time of your PC during recording the data.

## [Network map display] screen

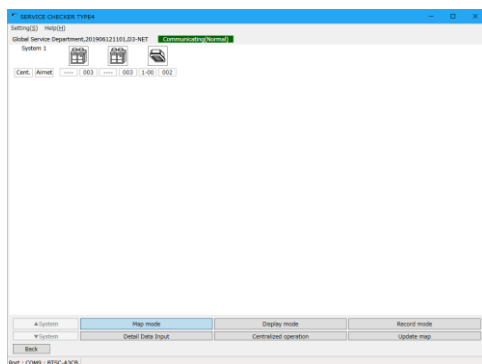

## (1) How to read this screen

- In this screen, outdoor and indoor units are shown as icon in the display order of auto-address
- Icon color will change by status of units

Color	Status
Red	In unit error
Violet	In communication error
Green	Indoor unit: Running Outdoor unit: Thermostat-on
Gray	Indoor unit: Stopping Outdoor unit: Thermostat-off
White	In case of unit model (series) not detected with the number of units were identified. For the first several minutes system is in this status during auto scan.

- In [Cent.] box, centralized group number is displayed. But this info is only sent while map is created, so this info cannot be shown if you used existing map.  
(if you entered group number in [Detailed data input], entered group number is shown.)
- In [Airnet] box, Airnet address is displayed.

## (Note)

1. If the color of icon is white, units are under detection. Operation data would not be displayed until completion of unit detection period will end. Please wait for until all icon will change to the color other than white.  
(If you start recording one of icon is still white (not recognized), data would not be recorded for those units)
2. [System] in the upper left corner means refrigerant circuit basis. It is possible to collect operation data of multiple refrigerant circuit system.
3. For VRV2 or later models, multiple outdoor unit system is supported, number of displayed outdoor unit icon could be more than actual number of total outdoor unit (due to reason of D3-NET data structure).

- (2) If it is not possible to display all units or system in one screen, please press [▲System] or [▼System] button in the bottom left corner in the screen to move the screen in vertical direction.



## 5-1-3 Switching modes

Buttons in the bottom row of the screen can be used by switching modes by buttons on the upper row at first then is pressed to execute desired function.

### A. Map mode

Map mode		
Detail Data Input	Centralized operation	Update map

[Detail Data Input]

Press to enter detailed information such as model name or installation place. Please proceed to "5-1-4 Detailed info input"

[Centralized operation]

If the centralized group numbers have been set, centralized control of indoor units can be executed. Please proceed to "5-3 Centralized operation"

[Update map]

Please press in case of addition/removal of the units or replacement of control PCB. Network map information will be acquired again to update.

(Note)

Units on the same D3-NET line will be in stand-by status (thermostat-off) for several minutes. Please be aware of that. After completion of this sequence, system will resume automatically.

### B. Display mode

	Display mode	
Disp. op data	Disp. Q'ty	

[Disp. op data]

Proceeding to [Operation data display] screen to check operation data of selected system. Please proceed to "5-1-5 Operation data display"

(Note)

Please proceed to Operation data screen after all icons turn to the color other than white.

[Number of units display]

Showing the number of connected outdoor and indoor units.

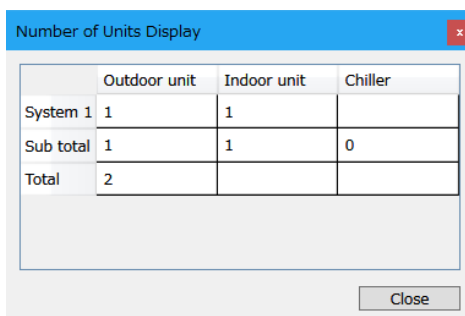

	Outdoor unit	Indoor unit	Chiller
System 1	1	1	
Sub total	1	1	0
Total	2		

Close

## C. Record mode

		Record mode
Period. rec set	Period. rec start	

[Periodic record set]

Proceeding to “Periodic record set” screen and setup data recording to PC data drive.  
Please proceed to “5-2-1 Setup PC recording”

[Periodic record start]

By pressing this button, data recording to PC drive will start. On the upper left screen, “Period Rcd” sign will be indicated. Button will change to “Period. rec end”, by pressing the button again to stop recording.

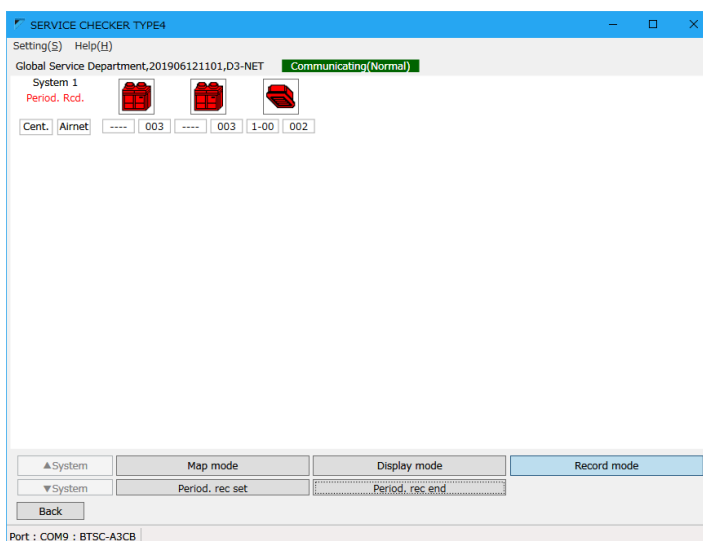
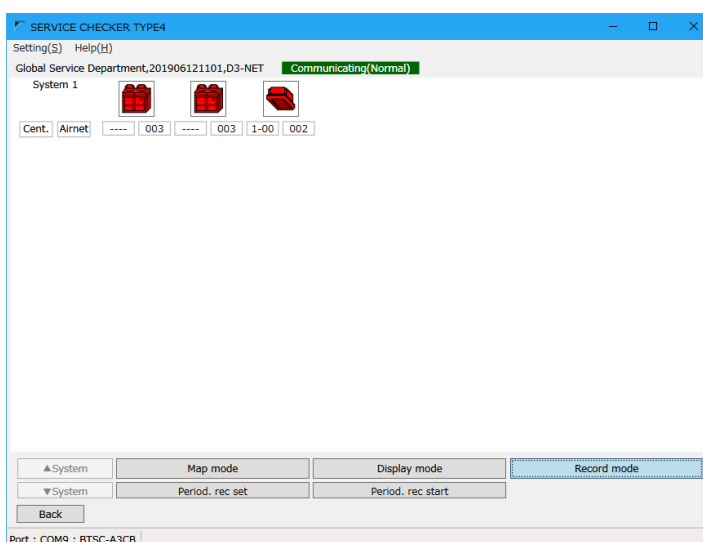

## 5-1-4 Detailed info input

Detailed information such as installation place for each unit (icon).

With this information, it becomes easier to identify each unit after second inspection onwards.

[Detailed Data Input] screen

Entry of detailed information is not obligatory.  
If it would not be utilized, there is no need to enter.

Please use in case of necessity.

In [Network map display] screen, by pressing [Detail Data Input] button in [Map mode], this screen will appear and detailed information of corresponding system can be entered.

### [Procedure]

- (1) In [1. Airconditioner selection], please select corresponding unit. The order of indoor unit is the order of auto address.
- (2) Please enter each item in [2. Detail data input]. Each item should be entered based on its necessity.

Item name	Description
Install site (name)	To provide information of installation place.
Model No.	To provide unit serial number
Model name	To provide unit model name. Rough category of product is pre-set. To provide more details, please select from list or enter info manually. Indoor unit does not have pre-set names so please enter name manually.
Centralized address	To provide centralized group number. Automatically acquired only during making new map. You can enter manually.
Auto address (not allowed to change)	Automatically acquired. In [Network map display] screen, icons are listed in the order of this address.
Airnet address (not allowed to change)	Automatically acquired. Address for Airnet is displayed in case of being set.

(3) Information entered please press [Save] button

(4) Select the other unit in [1. Airconditioner selection] and enter necessary field then press [Save] button

(Note)

- Once you replaced control PCB, auto address of network map will change.
- If you updated map, location of detailed information will move from appropriate place because detailed info of each unit is stored in the order of auto address. To correct this situation please re-arrange detailed info as the procedure instructed below.  
(auto address and Airnet address are not necessary to re-arrange)

Sample) Below case is a sample of re-arrangement of detailed info of I-1 and I-2.

- (1) In [Detail Data Input] screen, [1. Airconditioner selection], select [I-1] and press [List display] button. [Detail data list display] screen will be shown.

Detail Data Input

1. Airconditioner selection: I-1

2. Detail data input

Install site (name): Office A

Model No.: 1234567

Model name: FXFQ20P

Centralized address: 1-00

Auto address: 001

Airnet address: 002

Buttons: Save, List display, Cancel (Esc)

- (2) Select [I-2] which is destination and press [Copy] button, detailed info of [I-2] will move to [I-1]

Detail Data Input

Install site	Model No.	Model name	Centralized address
Global service department	1234567	RXYQ10P	----
Office A	1234567	FXFQ20P	1-00
Office B	2345678	FXMQ50P	1-01

Buttons: Copy (F1), Cancel (Esc)

- (3) Press [Cancel (esc)] button to return to [Detail Data Input] screen.

- (5) After finishing input, please press [Cancel (esc)] button to return to [Network map display] screen.

## 5-1-5 Operation data display

[Operation data display] screen

In [Network map display] screen, by pressing [Disp. op data] in [Display mode], operation data will be shown for selected system. 1 screen per 1 system will be shown.

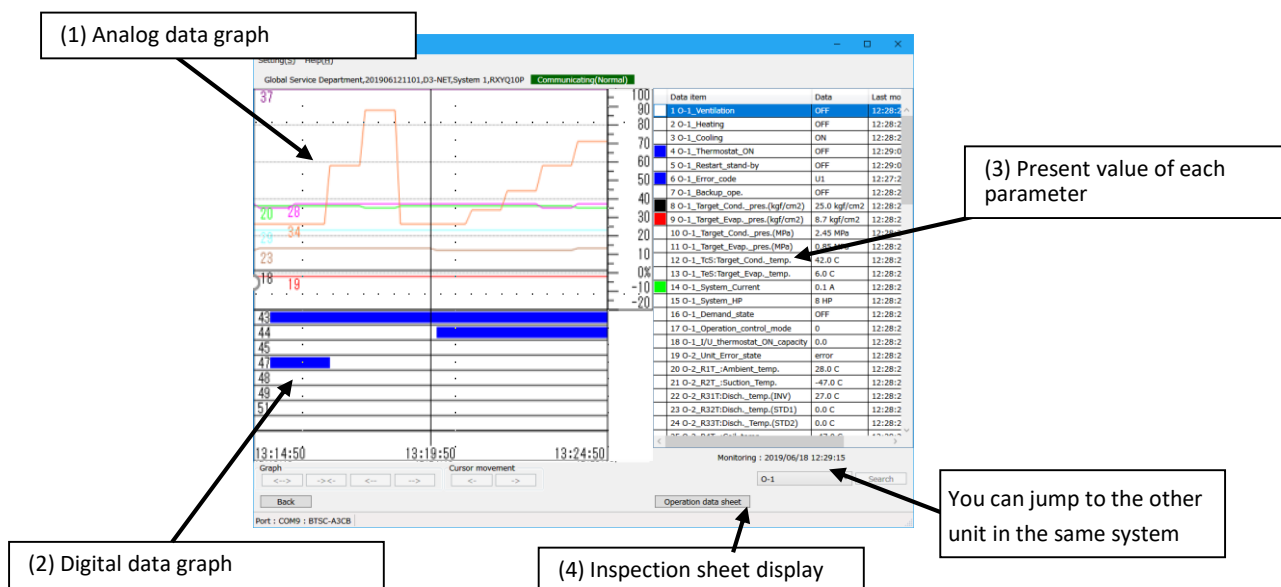

(1) Analog data graph (upper left)

- Showing time in horizontal axis, percentage from full scale (-20% - +100%) in vertical axis. The full scale value of each parameter is shown in the right most column of present value chart in the right. Please check them by scrolling the chart. At 100%, data is at full scale value.
- Number and color of graphs are corresponding to the number and color of square (□) in the left most column of present value chart in the right.
- Up to 8 items per unit can be displayed.

(2) Digital data (ON/OFF status) graph (lower left)

- In case of ON status, blue bar is shown.
- Number of each bar corresponds to the number of each parameter of present value chart.
- Up to 8 items per unit can be displayed.

(Note) About cursor (vertical line in the graph)

1. To display operation data from record mode, cursor is not displayed initially. The latest data is displayed in each box in (3) present value chart.
2. If a connected system is supported model by inspection sheet output function, by clicking on the graph area (or cursor move button), cursor will be displayed and parameters at the time of cursor indicates are shown in the (3) present value chart.
3. If a connected system is not supported model by inspection sheet output function, cursor would not be shown and status remains at 1.
4. In case of showing operation data from display mode, cursor will be shown initially in the middle of graph.

(3) Present value chart of each parameter (list on the right)

Listed item	Description
(far left column)	Colored square (□) is shown for parameter in the graph
Data item	From left, [data number], [classification of outdoor/indoor and number], [item name] are displayed
Data	Operation data value is shown In case of D3-NET connection, data refresh interval is in several minutes (1-5 min)
Last modified	Time of data updated is shown In case of D3-NET, some are updated in several minutes interval
Full scale	The value of 100% scale of each analog data

- Per unit, 8 analog data and 8 digital data can be displayed in the graph. Please select a desired parameter and click it again to show. Data will be shown in the graph screen with a colored square (□) will appear in the far left column.
- By clicking same data on the graph will hide it from the graph.

(Note) About data item

For small capacity models, there could be some sensor or actuator data which are not equipped. Please ignore those parameters. For more details please refer to service manuals.

## (4) Inspection sheet display

(4-1) Excel file export

(4-2) Reloading data in the sheet

(4-3) Outdoor unit info and data acquisition time is shown

(4-4) Manual input boxes

Unit No:2, Model No:O-2,O-3, Data time:2018/08/27 12:16:00

**VRV operation data sheet** Date:

Model	Serial number	System name/place				
<b>Unit operating conditions by data</b>						
Item	Symbol	Unit	Normal data range	Value*	Check point	Potential issues
Outdoor temperature		°C	Cooling -5~43°C(23~110°F) Heating -15~18°C(5~80°F)			Measure in the place without affection of discharged air
Outdoor temperature (unit sensor reading)		°C	Cooling -5~43°C(23~110°F) Heating -15~18°C(5~80°F)	18.0		
System operation current		A	Less than 25A	18.0		Deviation between phases<20%
Low pressure (evaporating)	Ps	MPa	0.5~1.0MPa	0.80		
High pressure (condensing)	Pd	MPa	2.4~3.4MPa	2.45	Not too low	Increment by control
Discharge pipe temperature	Td	°C	(Tc+20)~120°C (Tc+36)~248°F	65.0	Not too high	Blocked piping, EEV failure
Suction gas pipe temperature	Ts	°C	-	15.0		
Saturation temp at evaporation	Te	°C	Calculated from evaporating pressure	4.0		
Saturation temp at condensation	To	°C	Calculated from condensing pressure	42.0		
Suction superheat	Ts-Te	°C	Te+(2~20)°C Te+(3.6~36)°F (reference)	11.0	Not too large	Blocked piping, EEV failure

\* Some items cannot be measured based on connected models.  
In case of no need for inspection of impossible to measure, enter to "Value" cell

<b>Unit operating conditions by visual check</b>	
Item	Judgment
(1) Abnormal sound noise, vibration	YES - NO
(2) Exterior damages	YES - NO
(3) Corrosion, rust, abrasion, or other deterioration	YES - NO
(4) Oil leakage	YES - NO
(5) Dirtiness of heat exchanger	YES - NO

Outdoor 1 Outdoor 2

:Manual input  :Auto input

(4-7) Switch between outdoor units

(4-6) Auto filled from checker data

(4-5) Select judgment result

## (4-1) Excel file export

Inspection sheet will be exported as Excel file format.

If no Excel software is installed to your PC, Excel file export function would work.

## (Note) About the position of "circles"

If you open exported Excel file, "circle" symbol selected in the Judgment box might be in the offset position based on the Excel version.

## (4-2) Reload data

Reloading selected leakage data in [Operation data display] graph and updates inspection sheet values.

## (4-3) Displaying outdoor unit information listed below

- Unit No.: For some models, unit number of outdoor unit is shown.
- Model No.: Displays outdoor unit number (e.g. O-2 = outdoor unit 2)
- Data time: Time of data acquired in [Operation data display] graph

## (4-4) Manual input box

- Data box in pink background is required to enter/select manually.
- After clicking once, you can enter necessary values.

## (4-5) Select judgment result

- For judgment result area, you can select and put circle by clicking YES or NO.
- Values cannot be entered manually (YES/NO selection only).

(4-6) Auto filled from checker data

- Data box in pale blue background are data which would be filled automatically.
- Upon creating inspection sheet window or clicking “(4-2) Reload data” button, selected operation values in [Operation data display] screen will be reflected.
- By clicking you can enter values manually.

(4-7) Switch between outdoor units

- Inspection sheet per outdoor unit will be displayed.
- You can switch between outdoor unit by selecting tab.

(4-8) Supported model (May, 2019)

VRV3 (HP, HR, Q, W, S)
VRV4 (HP, HR, Q, W, S, i)
VRV5 (VRV-A, X, H, VRV4-U)

(5) By pressing [X] button in the upper right corner, return to [Operation data display] screen



## 5-2 Recording setup

### 5-2-1 Setup recording

In [Network map display] screen, by pressing [Period. rec set] in [Record mode], [Periodic record set] screen will appear.

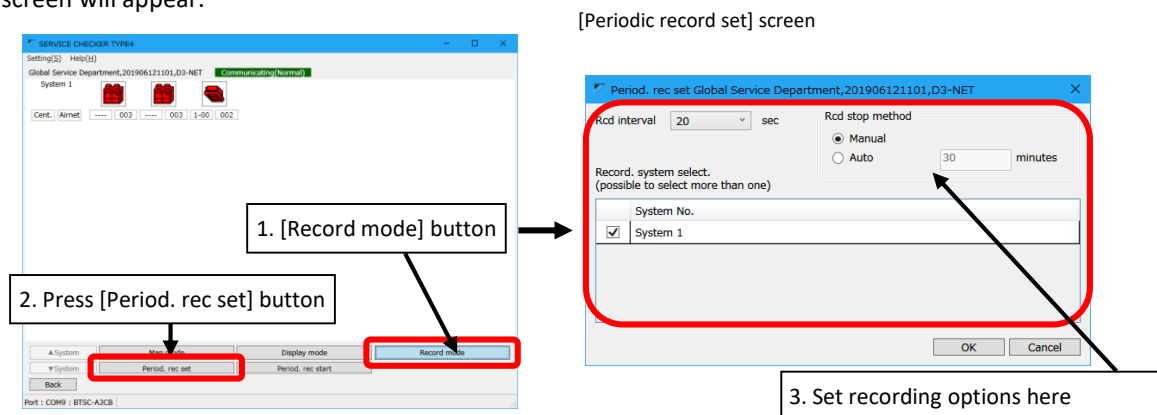

#### [Procedure]

(1) Set [1. Record interval], [2. Record stop method], [3. Record system select]

Set item	Description
1. Record interval	<ul style="list-style-type: none"> <li>Select record interval for writing data to PC data drive. Unit is second (5, 10, 20, 30, 60, 120, 180, 300, 600 sec)</li> <li>Normally 20sec as default set is recommended because shorter interval takes more disk space.</li> <li>To record data more than days, it is recommended to set interval as 120-300 sec to reduce data amount.</li> </ul> <p>Interval is time in between each record to be stored in PC hard drive but data update interval depends on specification of VRV units.</p>
2. Record stop method	<p>Please specify how to stop recording.</p> <p>Manual: Recording continues until [Period. rec end] button is pressed.</p> <p>Auto: Recording will end after the time specified in [Recording time] box. Please enter recording time in "minutes".</p>
3. Record system select	<ul style="list-style-type: none"> <li>It is possible to select record/not record by system basis. You can select multiple systems.</li> <li>Select check box for each corresponding system and click to check/uncheck.</li> </ul>

#### (Note)

Data update interval differs from model but normally it is fixed at between 1 to 5 minutes (this value cannot be changed by checker because it is defined by unit). So if you shorten recording interval to very short time such as 5 sec, same value would be recorded in multiple times.

\* Actual data updated time is displayed in present data chart in the right.

(2) To save changes, press [OK] button. To cancel changes, press [Cancel] button to return to [Network map] screen.

(3) To start periodic record to PC data drive, press [Period. rec start] button in [Network map] screen. "Period. Red." sign will be indicated in the upper left corner. Besides button will be changed to [Period. rec end]

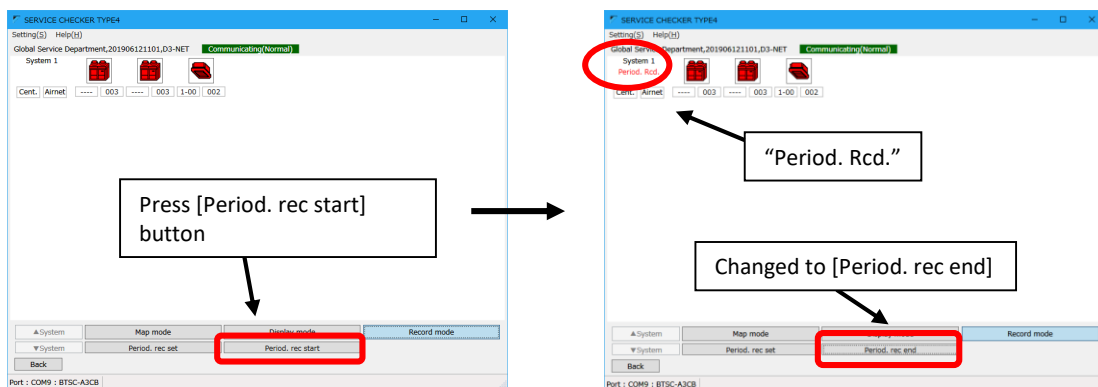

(4) If you need to manually stop periodic recording, press [Period. rec end] button. If you select [Auto] in [Record end method], recording will end in the set time automatically.

(5) In case of disconnection of communication with TYPE4 Checker box, [Communicating(Error)] will be shown. Please check connection and retry recording.

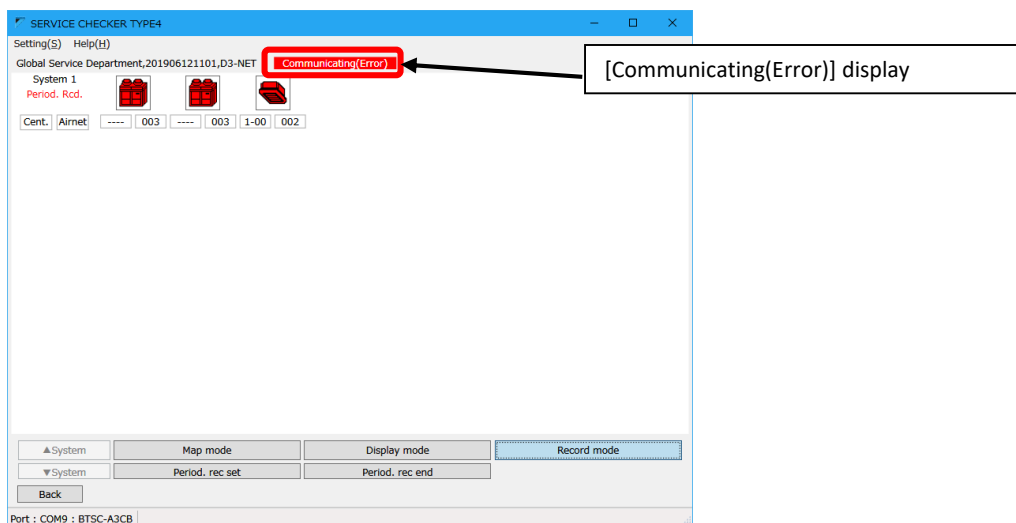

## 5-3 Centralized operation

Checker software has centralized operation function.

It is possible to do centralized operation from checker software instead of centralized controller.

To execute centralized operation, centralized group number needs to be set to desired indoor units beforehand.

### (Note)

If the centralized group number is not set yet, it is necessary to set them.

Connect TYPE4 checker box to D3-NET line and setup customer information from checker software, please show [Network map display] screen. With this condition, centralized operation will be possible if you set necessary centralized group number by indoor unit remote controller.

In [Network map display] screen, press [Centralized operation] button in [Map mode], [Centralized operation] screen will appear.

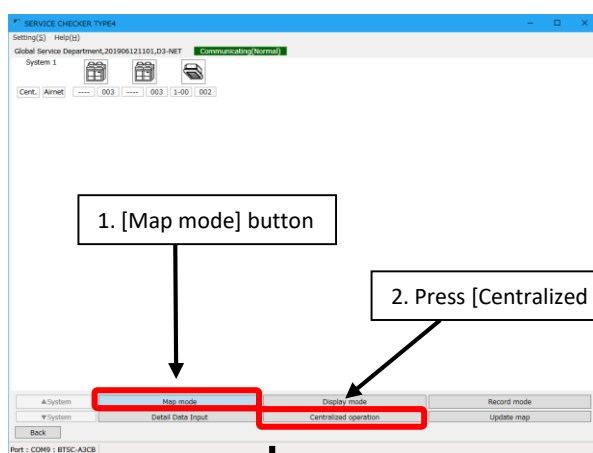

[Centralized operation] screen

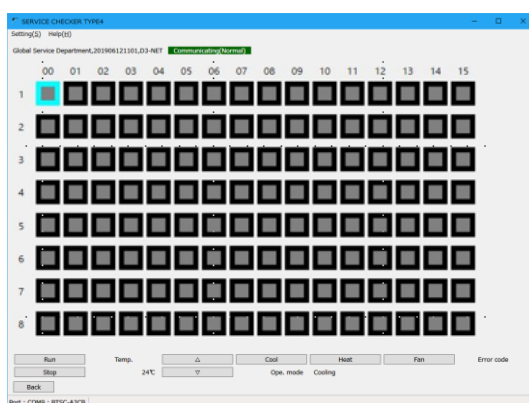

Color	Status
Red	Error
Violet	Comm. Error
Green	Running
Gray	Stop

- In this screen, indoor unit which can be controlled centrally are listed as icon in the order of centralized group number.
- Icon color will change based on the status

**[Procedure]**

(1) Select desired indoor unit icon and execute centralize operation such as alteration of set values, etc.

Button, box	Description
Run	Start selected unit
Stop	Stop selected unit
▲	Change setpoint, range of value is 0 to 35.
▼	* If specification of unit has value range of 16-32, even though you changed setpoint at 35 by ▲ button, value would change to 32 in a few seconds later.
Cool	Change operation mode to cooling
Heat	Change operation mode to heating
Fan	Change operation mode to fan only (ventilation)
Error code	In case of error, code will be indicated here
Right side of screen	<p>In the right side of this screen, status is indicated as remote controller shows.</p> <p>[Under center control] Master centralized controller does not allow slave controller. No centralized operations can be done by checker.</p> <p>[Under forced stop] Under status of forced stop control. No centralized operations other than stop command by checker.</p> <p>[Under centralized control] If other centralized controller has prohibited the operations of indoor units from manual operation by a remote controller, this sign is displayed on each indoor unit. The indoor units are not possible to operate other than stop.</p> <p>[Under operation shift control] In case of remote controller group or a Cool/Heat selector is connected to outdoor units, this sign is displayed when selecting an indoor unit impossible to change operation mode.</p>

(2) To exit this screen, press [Back] button.



(3) Operation data display screen

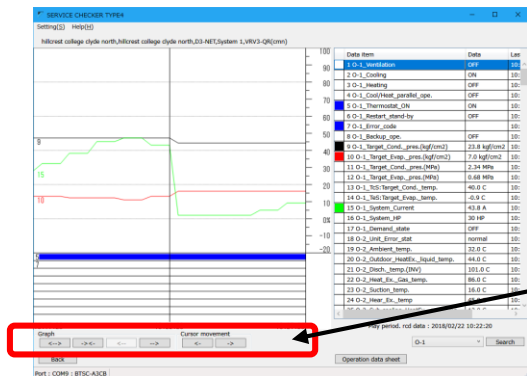

\* Details of operation data display, please refer to "5-1-5 Operation data display". If you click on the graph area, parameters on that time will be listed on the right. Buttons listed below will work for the graph displayed on the left.

Button

Button		Description
< - - >	Magnify	Make time scale (X-axis) of the graph smaller (short time line)
-> <-	Minify	Make time scale (X-axis) of the graph larger (long time line)
< --	Go back	Move timeline to backward (50% of X-axis time scale)
-->	Proceed	Move timeline to forward (50% of X-axis time scale)
<-	Left	Move cursor (vertical line) to the left
->	Right	Move cursor (vertical line) to the right

(4) Max/Min value of analog data and error code can be searched (digital data cannot be searched). Present value list in the right, click to highlight desired data item and press [Search] button.

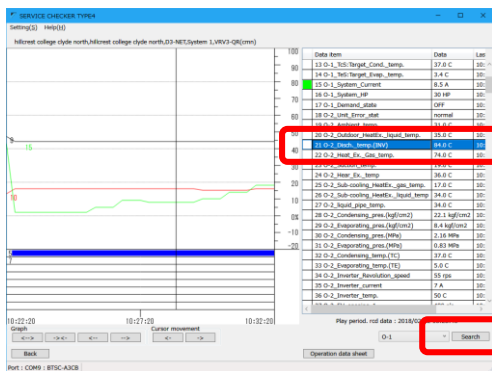

1. Select desired data

2. Press [Search] button

(1) Analog data

Enter search threshold value

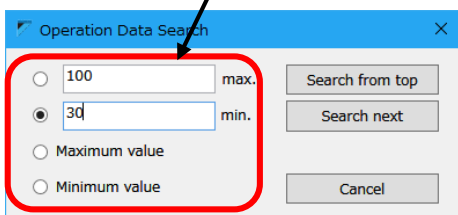

(2) Error code

Check operation data with error code

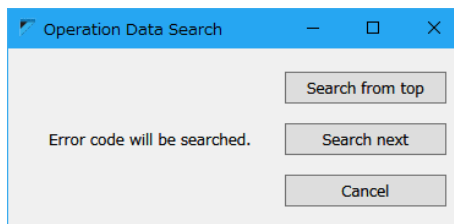

[Search from top]: Search from the first of operation data

[Search next]: Search from the point of cursor

[Cancel] : Return to operation data display screen

(5) Inspection sheet can be created by pressing button in the bottom of this screen.

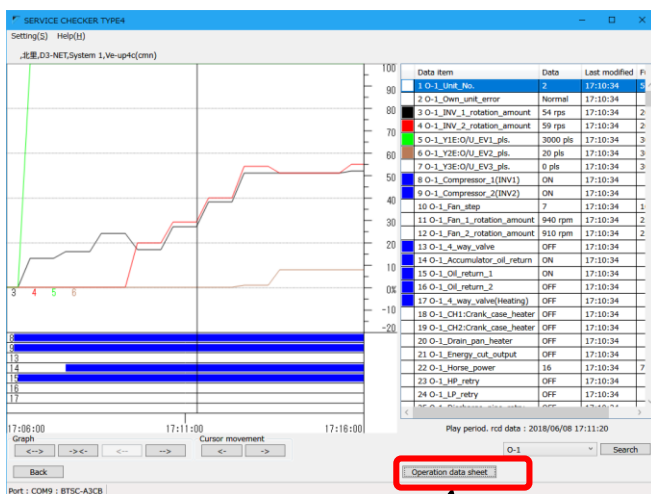

Create inspection sheet

- Please refer to [5-1-5 Operation data display] for details of inspection sheet

(6) By pressing [Back] button to customer data selection screen.





## (4) Network map display screen

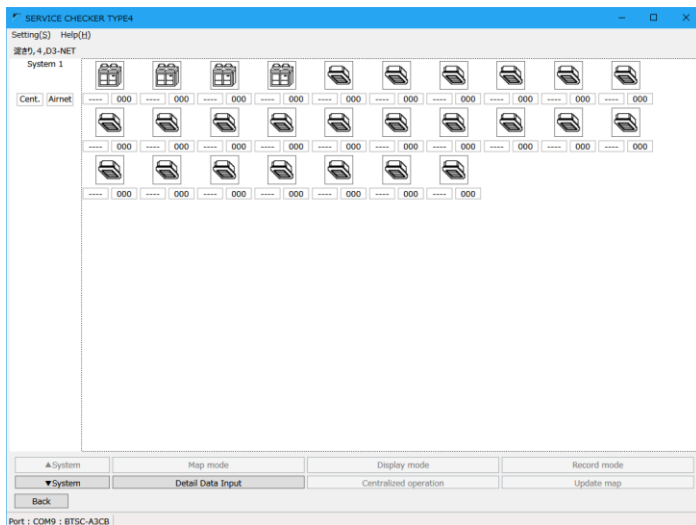

[▲System], [▼System]: Move between systems

[Detail Data Input]: Press in case of model/installation place info input  
Please proceed to [5-1-4 Detailed info input]

[Back]: Return to [Network map selection]

## 6-3 CSV output (export function)

To utilize recorded data by the other software such as Excel, data export to csv format is supported.

\*CSV format: comma separated value data

### [Procedure]

(1) In main menu, press [Play] button to [Customer data selection] screen

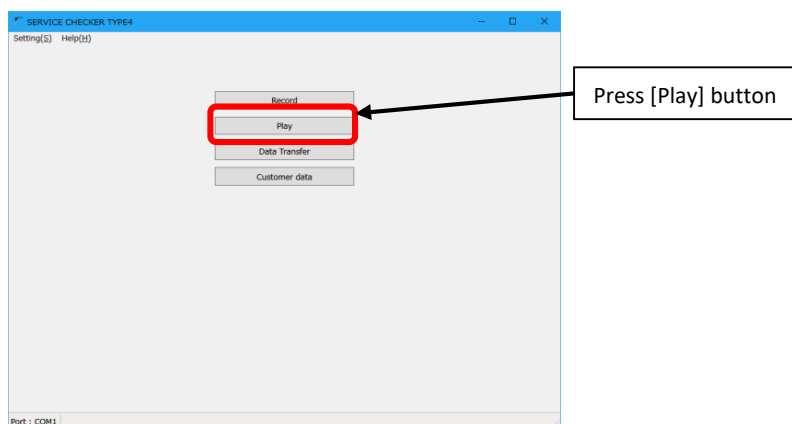

(2) [Customer data selection] screen

Select desired data and press [CSV data output] button

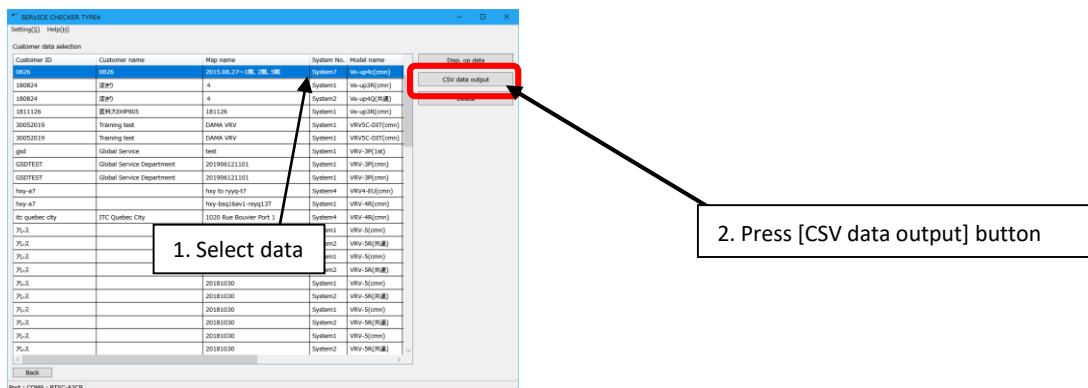

(3) [CSV output setting] screen

After output data period, header data relevant settings, press [OK] button to proceed.

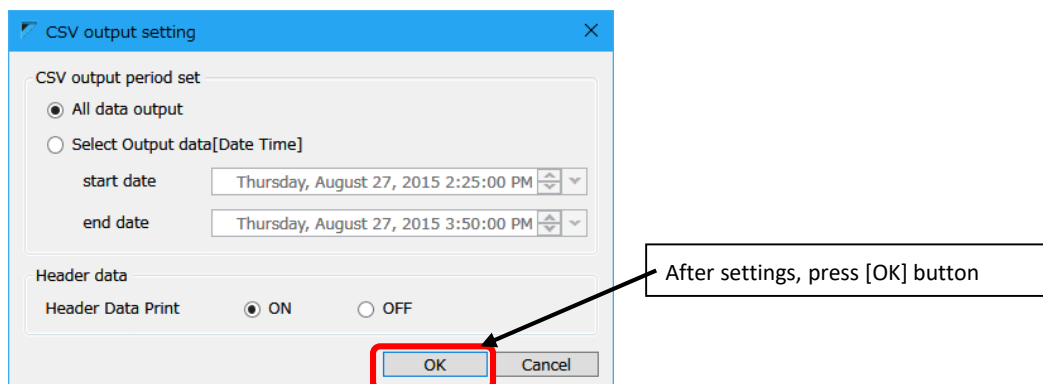

CSV file output period setting	
All data output	All recorded data will be exported to csv file
Select Output data	Narrow down data period which will be exported to csv (reduction of export time and file size)
Header data setting	
ON	Export site, equipment, data information header to csv file
OFF	Data only export without header rows (good for auto process by the other tools)

(Note)

1. CSV file will be exported 1 file per unit (both outdoor/indoor)  
For example the system with 1 outdoor unit and 8 indoor unit, 1 csv file for outdoor unit and 8 csv files for indoor units will be exported.
2. If recorded period is too long to store all data in one csv file, it could be exported in multiple files.

(4) [Save As] screen. Select location to save and enter file name, then press [Save] button

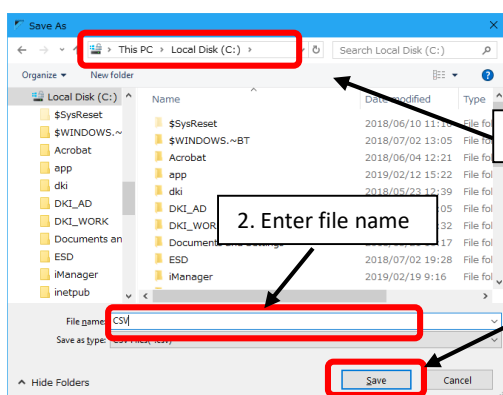

1. Select location to save

2. Enter file name

3. Press [Save] button

File name rule

Specified file name\_Ou01.csv

: for outdoor unit

Specified file name\_In01.csv

: for indoor unit

(number will differ based on the connected number of units)

(5) During CSV file export, below screen is shown

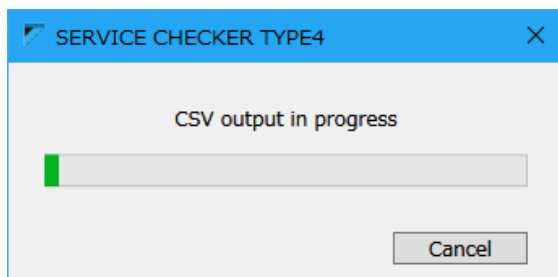

# Chapter 7: Other functions

## 7-1 Data transfer

Recorded operation data or customer data can be transferred or sent by the storage media such as USB stick drive. To execute this, [Data transfer] function is used.

(Note)

- Data can be copied directly from PC folder location by Windows explorer, it is not easy to locate them so it's much more convenient to use this function.

### [Procedure]

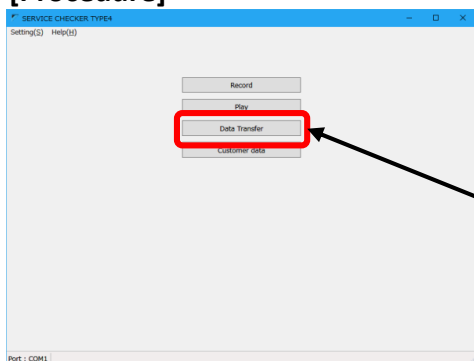

(1) In main menu, press [Data transfer] button to proceed to [Data transfer] screen

Press [Data transfer] button

Select location to/from copy

(2) Data transfer screen

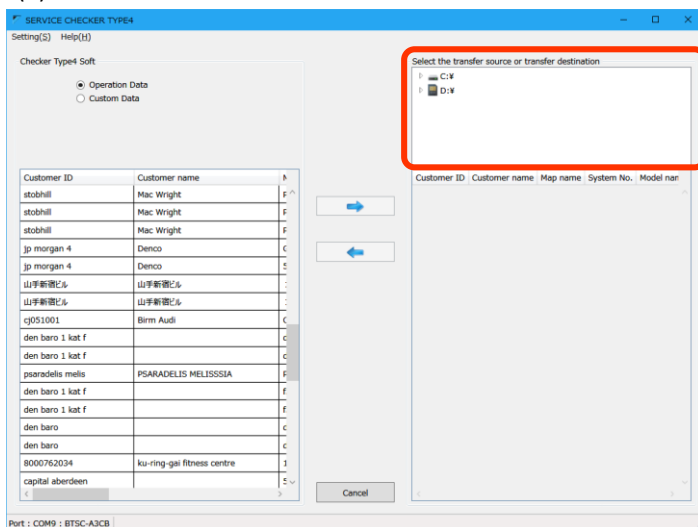

- Left side is data list which checker stores in your PC (fixed).
  - Right side is destination to/from transfer. It is possible to select folder name.
  - Unit of transferring data is;
    1. Operation data and customer info
    2. Customer info only
- \* Network map information is included in customer information.

## 1. Transfer operation data and customer information

### ➡ Exporting data (to storage media)

1. Select operation data or customer information on the left to transfer.
2. Select destination folder in the right side of the screen.
3. By pressing right arrow [➡] button to start transferring.

### Importing data (from storage media or folder)



1. Select operation data or customer data information on the left as importing destination.
2. Select origin folder in the right side of the screen.
3. Select operation data to import from the right.
4. By pressing left arrow [←] button to start importing.

\* If there are same name of operation data in the destination, below dialog will be shown.

The dialog box is titled "Confirmation" and contains the following text and fields:

Same customer data already exists

Current customer data

Customer ID	aotc	System No	1
Customer name	AOTC	Record start time	2019/02/01 16:54
Network map name	1-2-19	File size	19KB

Overwrite the following new customer data?

Customer ID	aotc	System No	1
Customer name	AOTC	Record start time	2019/02/01 16:54
Network map name	1-2-19	File size	19KB

Buttons: Yes, Yes to all, No, Cancel

[Yes] : Overwrite this data only

[Yes to all] : Overwrite all data to import

[No] : Not overwrite this data and skip to next data

[Cancel] : Abort transferring operation

\* If there are same name of customer data in the destination, below dialog will be shown.  
Meanings of each button are same as above.

The dialog box is titled "Confirmation" and contains the following text and fields:

Same customer data already exists

Current customer data

Customer ID	180824
Customer name	淀きり

Overwrite the following new customer data?

Customer ID	180824
Customer name	淀きり

Buttons: Yes, Yes to all, No, Cancel

## 2. Transfer customer information only

Other than selecting [Customer data] on the upper left, procedures are same as 1. Transfer operation data and customer information.

(3) Press [Cancel] button to exit

## 7-2 Customer information

Checker software manages operation data by customer basis. Therefore customer ID is mandatory field to enter in customer information. If the operation data is recorded from [Record only] without managing data by customer information, every time VRV unit will be D3-NET initialization status and thermostat-OFF condition. So customer information management is highly recommended.

(Note)

Other than [Customer data] menu, customer information can be entered from [Record] menu.

### [Procedure]

(1) In main menu, press [Customer data] button to proceed to [Customer selection] screen.

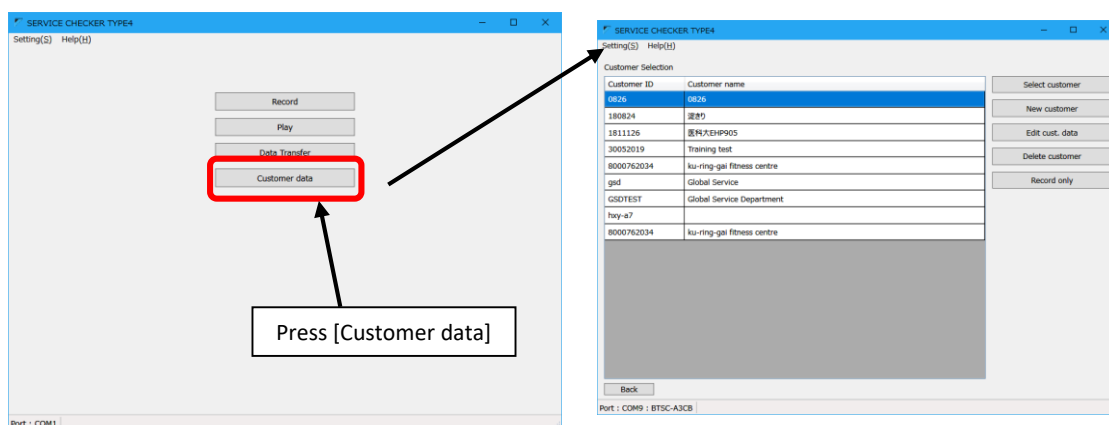

(2) To create a new customer, press [New customer] button to proceed to below screen.

Customer ID	007
Customer name	Daikin Industries
Section	
Person in charge	
Address	
Telephone	
Customer FAX number	
Remarks	

- To edit existing customer information, select desired customer and press [Edit cust. Data] button.
- To remove existing customer information, press [Delete customer] button

(3) [Customer ID] is used for distinguishing customer, please enter in alphanumerical characters.

(4) [Customer name] is displayed in [Operation data selection] screen etc. It is highly recommended to enter.

(5) Other items are entered based on their necessities (they are not mandatory fields).

(6) After finishing entry, press [Save] button. Return without saving, press [Cancel] button.

## 7-3 Option setting

### 7-3-1 Setup COM port

Selecting communication port which is connected to checker.

On PC side, installed (available) communication ports are managed as COM number. Please use appropriate COM port number to communicate. Default selection is COM1.

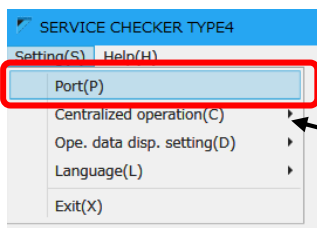

If this setting is not correctly done, communication error takes place. (see [1-2-3 Required to do before recording] for more details)

(1) Press [Port(P)] in [Setting(S)] menu

(1) Select COM port to use

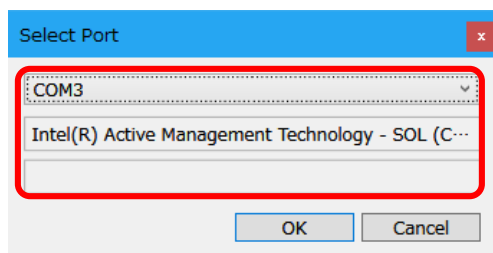

Click the top box (list) and select COM port from listed port number. From listed COM port numbers, please select COM port number which comes with “Silicon Labs CP210x USB to UART Bridge” in the middle box.

Note) In case of no COM port with “Silicon Labs CP210x USB to UART Bridge”

It is necessary to install driver files of USB serial port.

Please obtain appropriate driver installer files from your local Daikin representative, or could be downloaded from below URL.

<https://www.silabs.com/products/development-tools/software/usb-to-uart-bridge-vcp-drivers>

(3) Press [OK] button to save changes

## 7-3-2 Prohibit/permit centralized control

It is possible to stop sending centralized control command from checker by this setting.

Checker has a centralized operation function, it regularly transmits data as a centralized controller to the connected D3-NET line.

To prohibit centralized control by this function, data transmission as centralized controller can be stopped by checker.

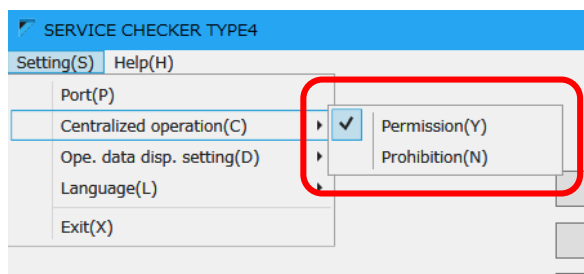

This setting can be changed from the menu shown left.

Default set value is "Permission"

Besides, this setting is reverted every time software starts up back to default value (Permission). Changed value would not retain.

\*After restarting software, set value would change to "Permission", if you need to continue "Prohibition" it is necessary to change this setting every time.

[Purpose of this function]

- 1) It cannot be added any devices which might cause influences to D3-NET communication. In case of a lot of units connected to the same D3-NET line and communication is very busy, but it is necessary to capture data without affection to D3-NET.
- 2) Under circumstance of no centralized controller is allowed to connect, but it is necessary to capture data. Or existing supervisor controller such as BMS controls VRV units by KRP2A or KRP4A. (see Q-101)

[Limitations]

If the centralized control function is prohibited, limitations listed below will apply.

- 1) No centralized control can be done from [Centralized control] screen.
- 2) No new data acquisition can be done because D3-NET initialization to obtain unit information. (in case of connecting checker to systems for the first time, at first temporarily permit centralize operation and create a new network map. Then prohibit centralized control again.)



### 7-3-3 Change display language

GUI language can be switched in between Japanese, English, and Simplified Chinese. Change will take effect after restarting the software.

(By change of language, some units could not be correctly monitored due to model info incompatibility)

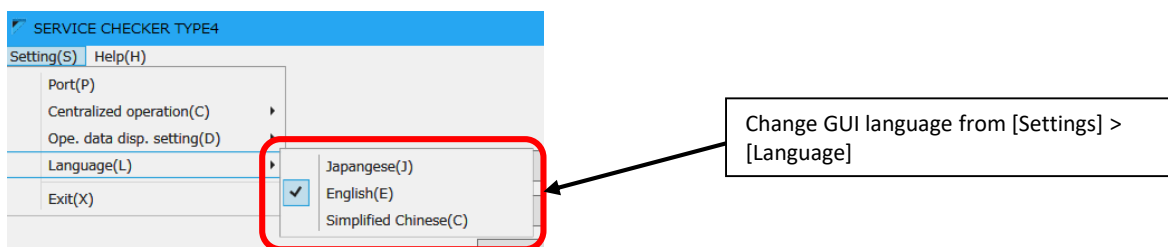

### 7-3-4 Change display unit of measure (temperature/pressure)

Unit of measure (temperature/pressure) can be selected from Celsius;kgf/cm2 or Fahrenheit+psi.

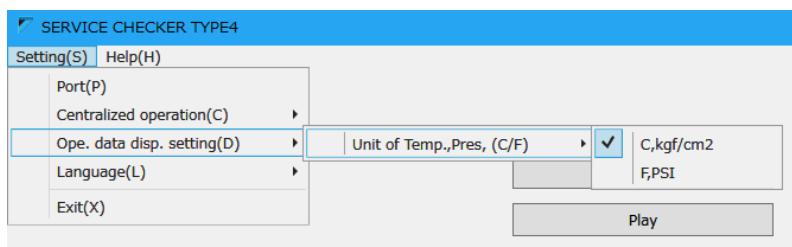

### Others: Changing window size

Operation data windows size can be changed by mouse operation.

(display area ratio of graph/present data chart cannot be changed)

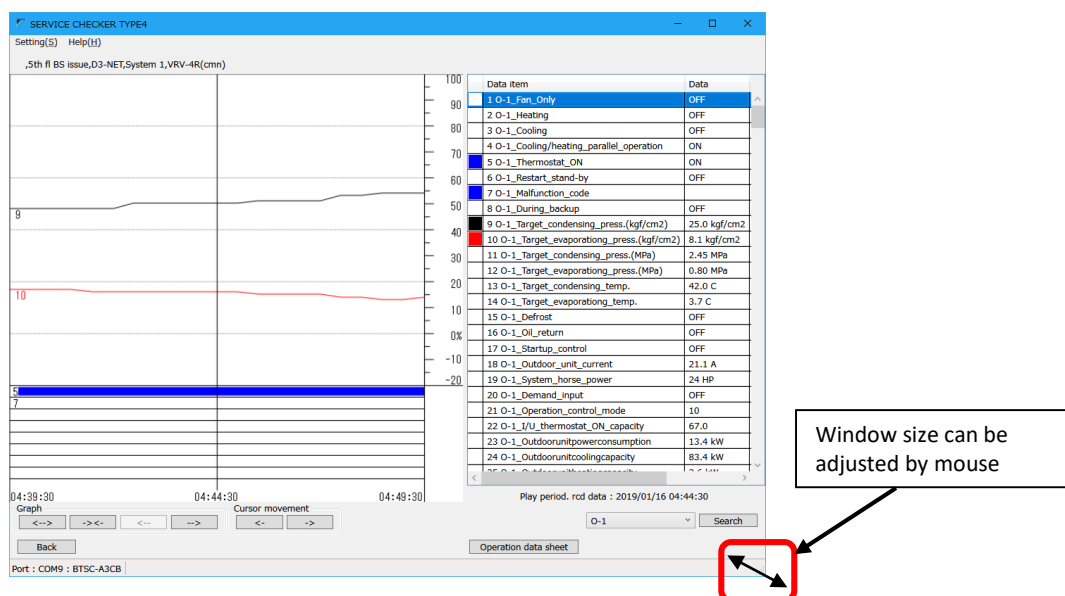

## 7-4 Help function

By help function, information listed below can be checked.

(1) Help	Display help screen
(2) Connection guide	Show wiring guidance screen to show how to connect TYPE4 checker and VRV
(3) Support models	Supported model list can be checked by PDF file.
(4) Version	Software version

### 1) Help

Showing help (manual) screen

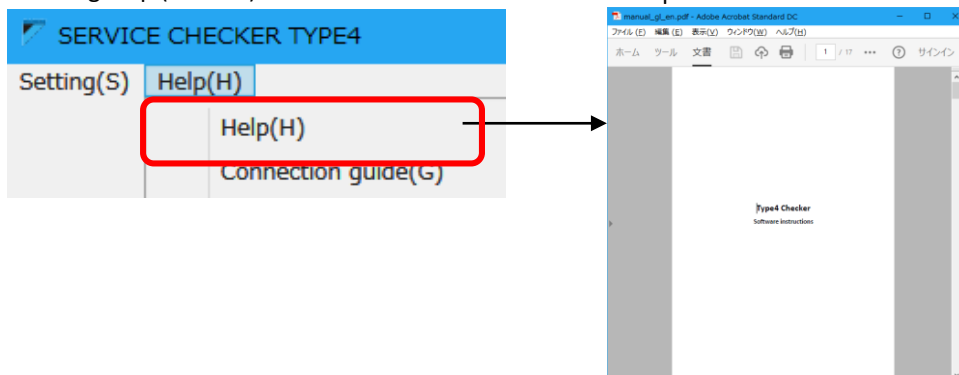

### 2) Connection guide

Showing how to connect TYPE4 checker to VRV

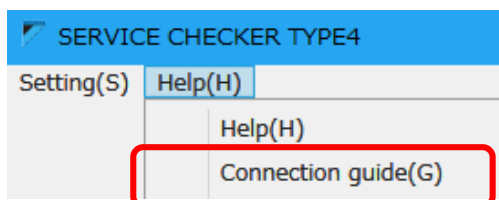



## Frequently asked questions

### ■ D3-NET related topic

#### [Q-101]

Error is generated if checker is connected to the system which Wiring Adaptor for Electrical Appendices (1) or (2) (KRP2A or KRP4A) adapter is installed.

#### [Phenomenon]

The other supervising system (BMS) controls VRV via Wiring adapter for electrical appendices and checker is connected to this system, supervising system causes air conditioner error.

#### [Cause]

Wiring Adaptor for Electrical Appendices (1) or (2) (KRP2A or KRP4A) cannot coexist with the other centralized controllers because centralized controller's operation command conflicts with the commands from the supervising system. Checker has centralized controller function, adapter sends status of centralized controller conflicted condition to BMS. This error itself is just a warning and does not affect operation of VRV system, but BMS system recognizes error status and record it in its history. Besides VRV system will be in restart stand-by (thermostat-off) due to connection of checker to the D3-NET line. As a result, it looks like VRV system stopped by error due to connection of checker.

#### [Countermeasure]

By connecting checker, error will be submit to supervising system. But VRV system itself is not affected and can be running without errors. After the removal of checker, alarm on supervising system will stop. In this case countermeasures listed below are possible to take.

1. Asking customer to ignore alarms while checker is connected (in case of short term connection).
2. Using checker option "Centralized operation prohibition mode"  
If a network map is already made before, checker can be disabled to work as a centralized controller by this option (please be aware every time checker software is launched it is necessary to change this option).  
Please refer to [7-3-2 Prohibit/permit centralized control]
3. Cut J5 wire of KRP4A adapter PCB to kill alarm related to function for duplication of centralized controller.  
\*Please be aware if this wire is cut, duplication of centralized controller can no longer alerted.

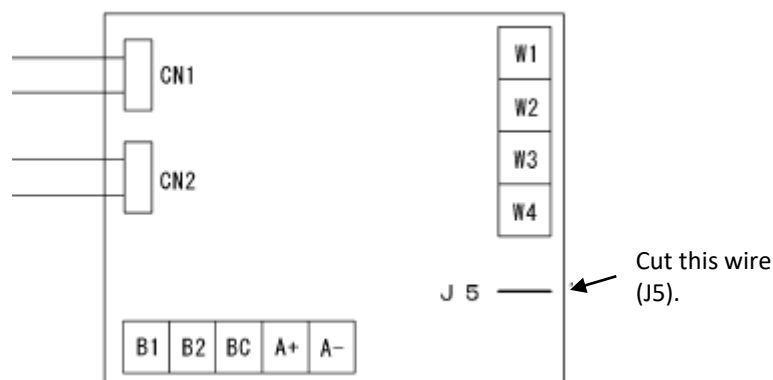

## ■ Software related topic

### [Q-201]

About software update

[Countermeasure]

Download update software from Daikin Europe Business Portal site:

<https://my.daikin.eu>

### [Q-202]

When trying to install the checker software, alert dialog is shown and installation cannot be executed.

[ Windows 7 ]

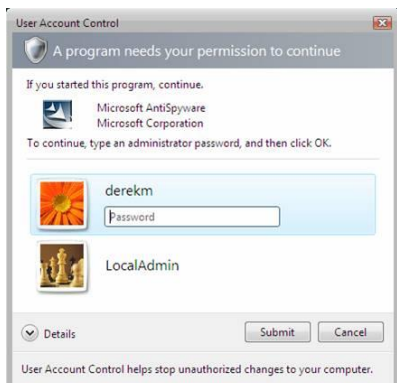

[ Windows 10 ]

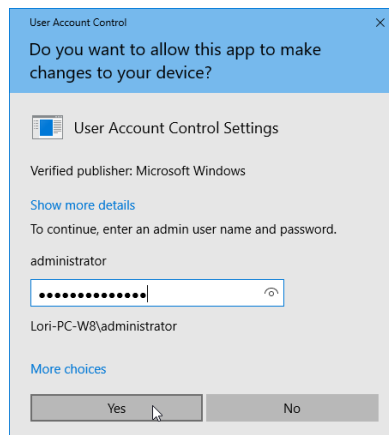

[Cause]

No access rights of software installation is available for your PC user account.

[Countermeasure]

Ask your IT administrator for software installation permission or login with administrator level password to your PC if you have administrator right but not logged in with administrator account.

**[Q-203]**

About frequently asked error message and possible actions (communication between PC and checker)

**[Error: 5-3]**

	Message	Port could not be opened.
1	Probable causes	Selected COM port number does not match with actual COM port which is connected to the checker. Default setting of COM port number is "COM1". If the checker is connected to the other port number, your PC cannot communicate with the checker.
	Measures	Please change COM port number which matches with your PC COM port.
2	Probable causes	PC COM port is already used by the other software or occupied by the other software which did not correctly quit.
	Measures	Quit the software which is using COM port. If COM port will be still occupied, please restart Windows.

**[Error: 6-1]**

	Message	Failed to start. Check connection.
1	Probable causes	Selected incorrect COM port number.
	Measures	Check the COM port which is connected to checker cable and change to valid COM port number from option menu of checker software.
2	Probable causes	Faulty connection between PC and checker. a. Connected to incorrect port (connector)? b. Invalid cable is used? c. Faulty cable (poor contact, disconnection ,etc.)
	Measures	Check connection status of PC communication port, connection cable condition or try another connection cable.

## ■ Unit related topic

### [Q-301]

All parameters persist on same value (do not change at all)

[Cause]

Checker records operation data received from VRV units, but if no communication data comes, the last parameters which was correctly received are recorded instead of blank, --, or 00. Thus if there is no data is available due to disconnected wiring or electric interference, same value (last correctly received data) is recorded after this point.

[Countermeasure]

Check and correct D3-NET wiring.

### [Q-302]

Even if an error code is indicated on the remote controller such as L5 (inverter overcurrent), checker does not show the corresponding error code. There are no inverter retry (stand-by).

[Cause]

Normally L5 (inverter overcurrent) error immediately stops compressor, then the direct cause of L5 error disappear and error status will be automatically reset. Like this kind of instantaneous state error codes, remote controller retains the error code even the error status itself will be removed. But checker dose not have such a function (retaining instantaneous error code until user reset operation), so these error codes cannot be captured.

[Countermeasure]

It is not possible to make checker to do same behavior as remote controller does due to technical difficulties (timing of cancellation of error status differs from model/series). Please check them by the other parameters such as inverter current value or others.

## ■ VRV model compatibility topic

### [Q-402]

In map mode screen, outdoor unit icon is displayed but no operations data is shown. Besides outdoor unit icon remains white and would not change to the other colors.

[Cause]

Operation data cannot be displayed because the software cannot recognize the outdoor unit. Outdoor unit data format differs from model/series which requires update of checker software to collect operation data. Therefore if connected outdoor unit is not supported yet, checker software can recognize it as an outdoor unit but it cannot recognize model information and collect operation data.

[Countermeasure]

Software update to the version which supports connected model or later. Please refer to the supported model list.

# Specification

## ■ Specification list of TYPE4 Checker

Item	Spec
Dimension	125(W) x 85(D) x 40(H) mm
Weight	200g (approximately)
Power supply	5V DC 200mA
Power input	1W (approximately)
Operating temp/RH	-10~55 deg, 95%RH or below (only except for condensation status)